

MVG[®]

Die Anhängerkupplung.

Anhängerkupplungen
und Elektrosätze
direkt vom Hersteller

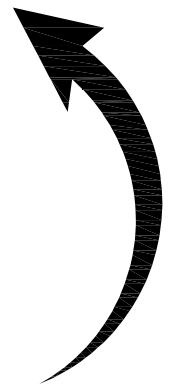
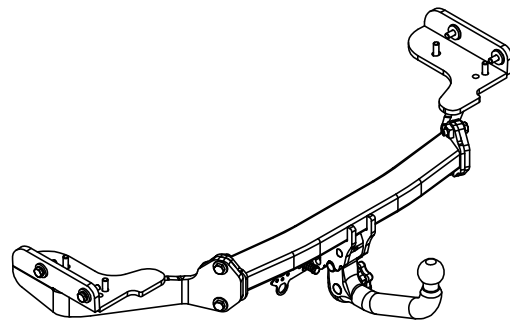
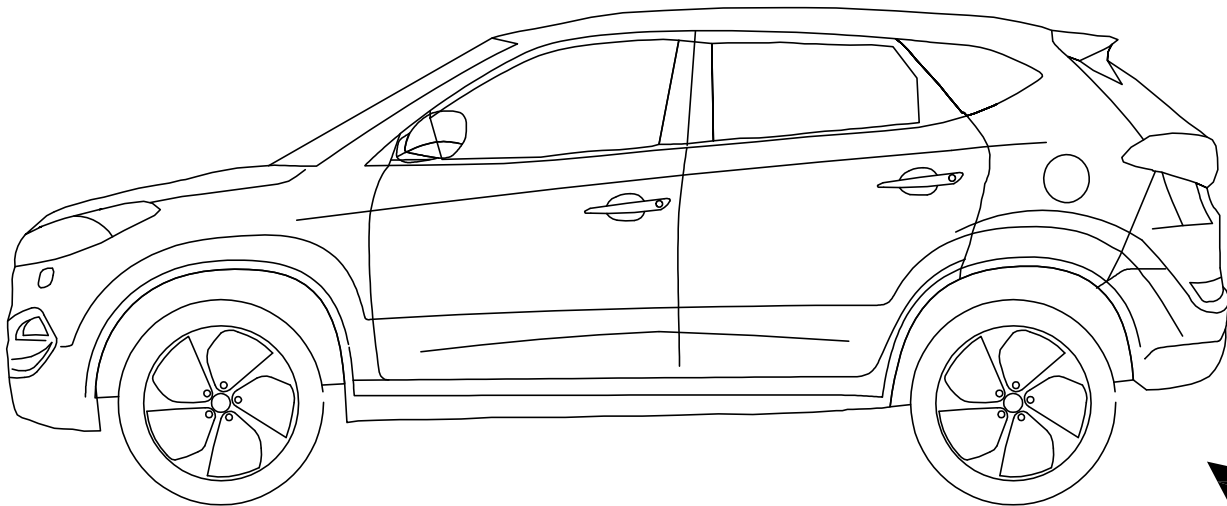

MVG: 3120 A

Hyundai Tucson (TLE)

(E) Instrucciones de montaje

(D) Einbauanleitung

(GB) Installation instruction

(F) Notice de montage

(NL) Inbouw instructie

(S) Monteringsanvisning

(CZ) Návod k montáži

(I) Istruzioni di montaggio

An der Wasserwiese 1
D-52249 Eschweiler

info@mvg-ahk.de
www.mvg-ahk.de

Tel.: 0049 (0)2403/7902-60
Fax: 0049 (0)2403/7902-99

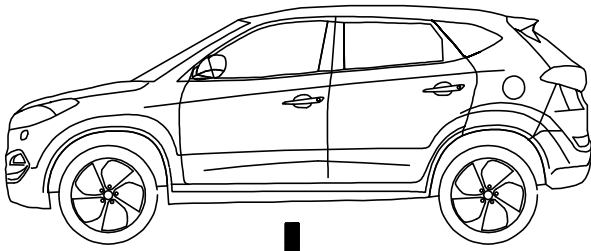

≤ 2250 kg



EG

e11 * 2007/46 * 2724

$$D = 11,2 \text{ kN}$$

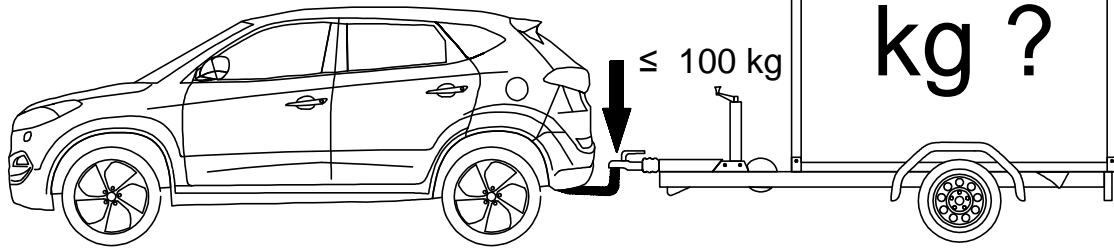

$$D = \frac{T \times R}{1000 \times (T + R)} \times g$$

$$g = 9,81 \text{ m/s}^2$$

$$T = \frac{R \times D \times 1000}{(g \times R) - (1000 \times D)} \times g$$

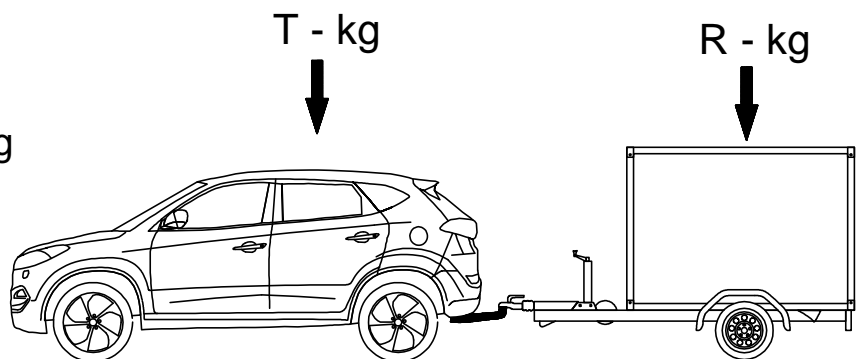

$$R = \frac{T \times D \times 1000}{(g \times T) - (1000 \times D)}$$

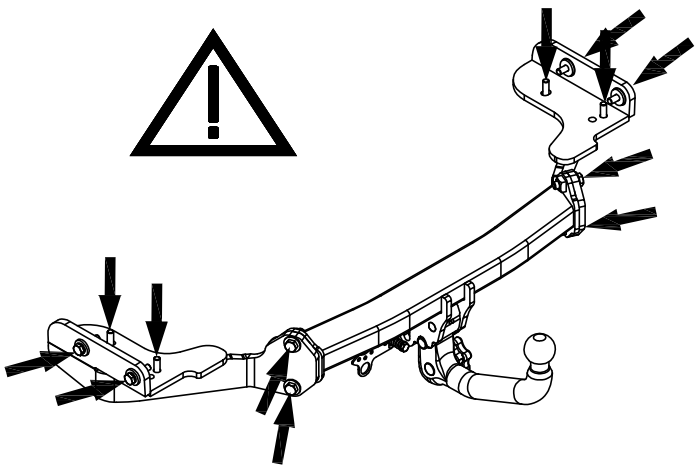
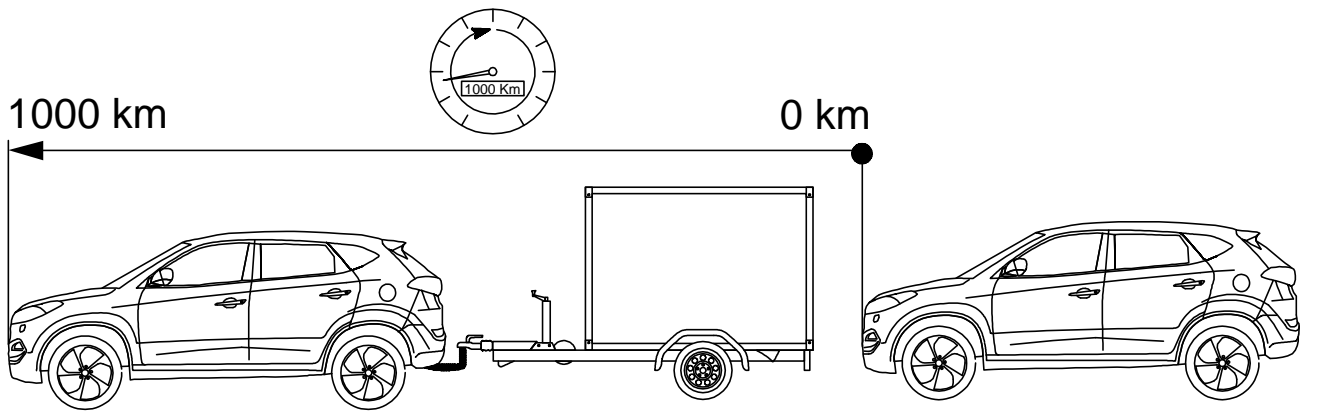
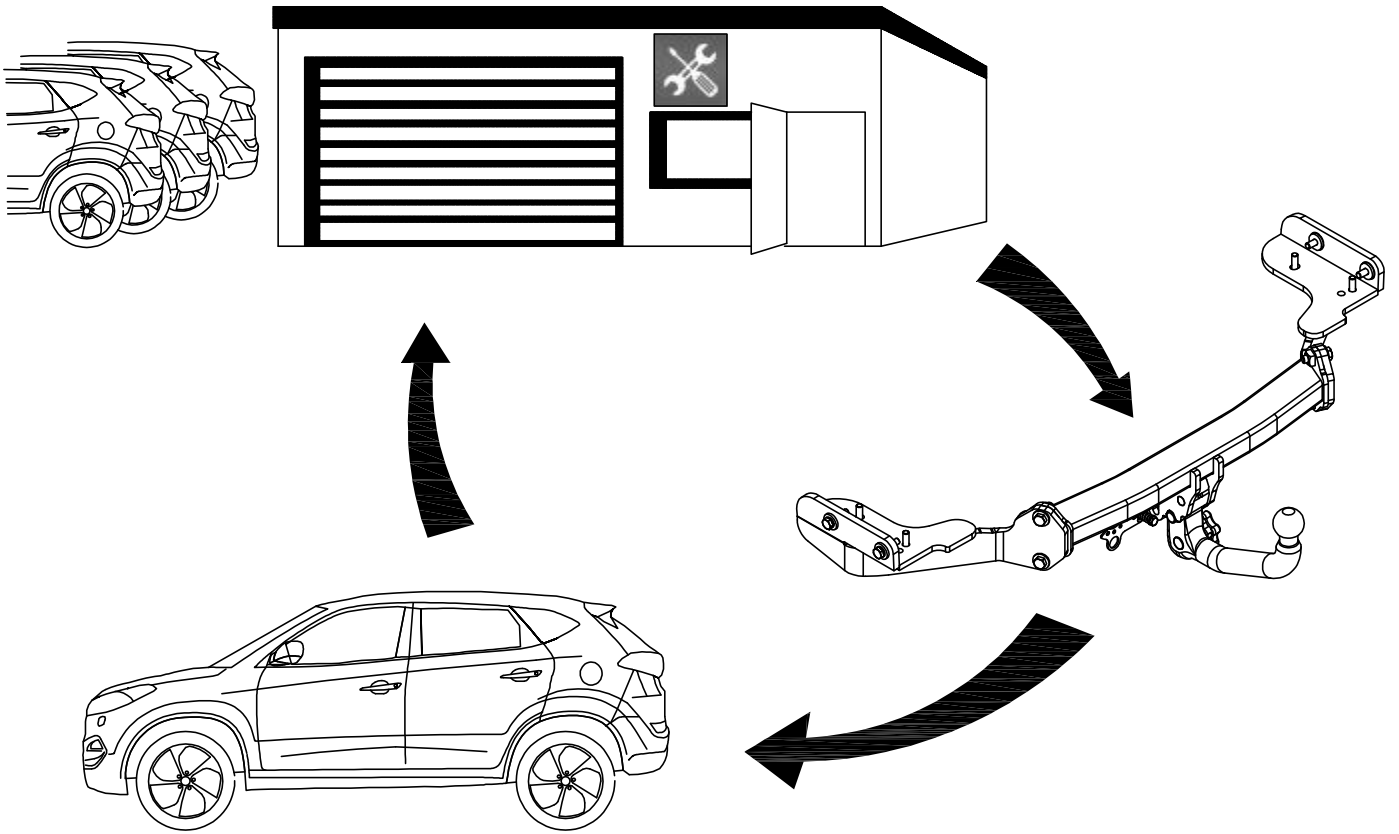

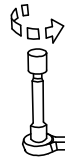
	M10	40 Nm
	M12	

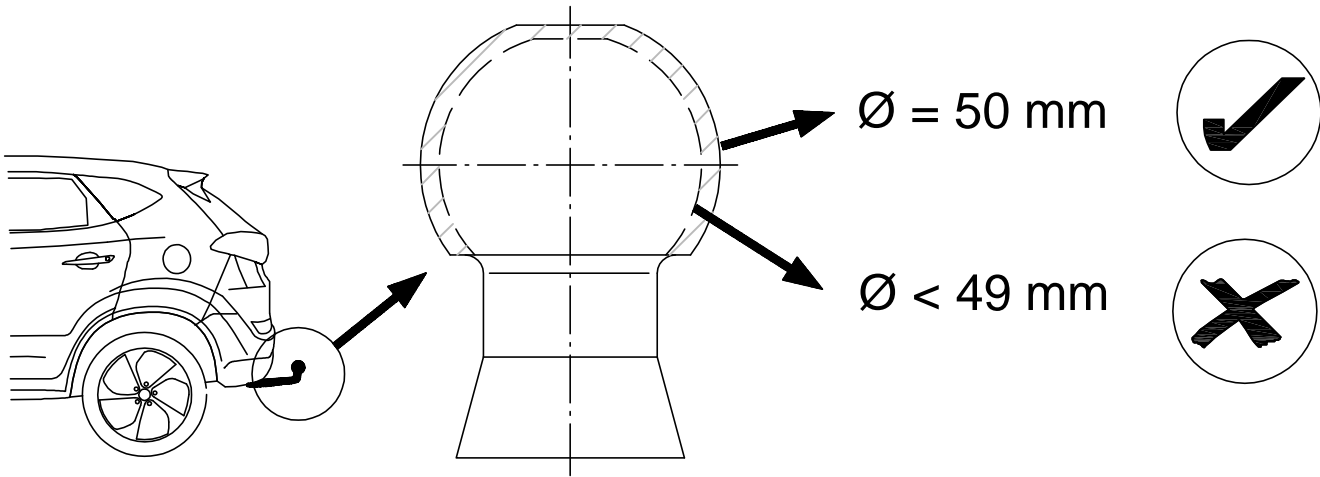

MVG[®] Approval Number
 (E4) 55R-01 0722
 Type: 3120 A D-Value: 11,2 kN
 Class: A50-X S-Value: 120 kg
 Made in Germany www.mvg-ahk.de





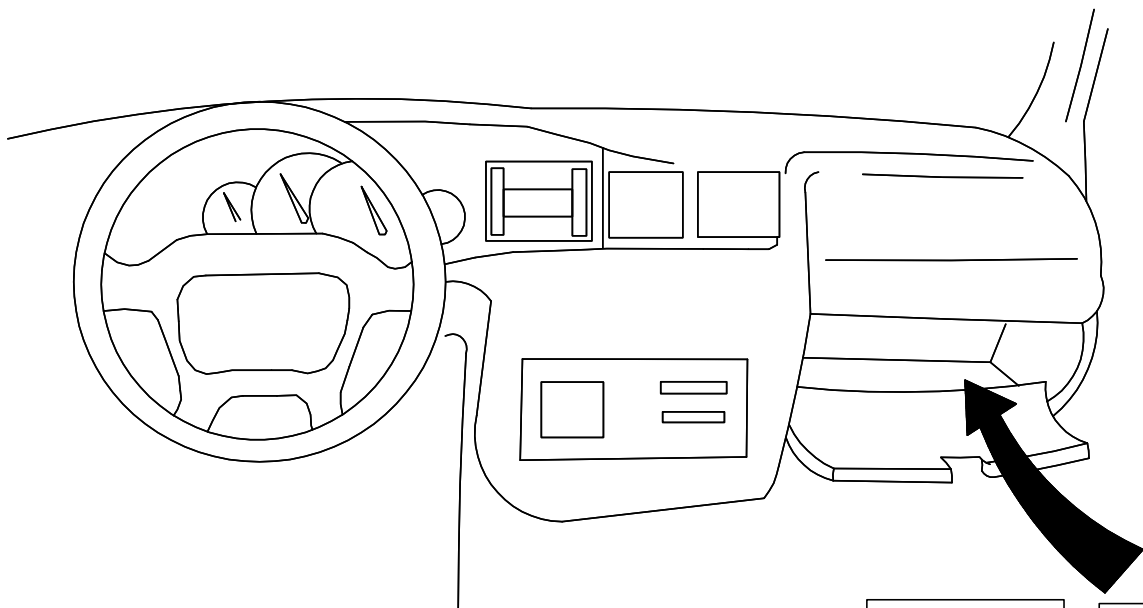



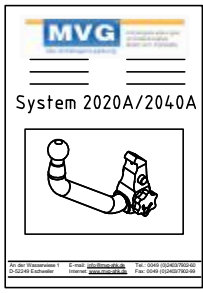
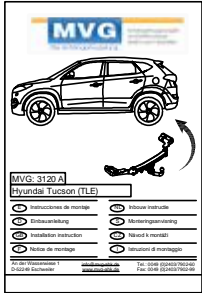











Zulässige Stützlast
 maximal 100 kg

MVG[®]
 MVG-Metallverarbeitungsgesellschaft mbH
www.mvg-ahk.de



Technische Änderungen vorbehalten

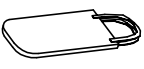

1	1x		3120 A		
2	1x		2020-A-13.1 / 2040 A 013		
3	je 1		(1 x rechts & 1 x links)		
4	8x		M10x1,25x40 (8.8) ISO 8676		
5	12x		Ø 10,5/28x4	DIN 6340	
6	8x		B10	Fst.	DIN 127
7	4x		M12x40 (8.8) ISO 4017		
8	4x		Ø 13/24x2,5	ISO 7089	
9	1x				
10	1x		M8x45 (8.8) ISO 4017		
11	1x		Ø 8,4/16x1,6	ISO 7089	
12	1x				
13	1x				
14	2x		Ø 8,4/16x1,6	DIN 125 PA 6.6	
15	1x		M8 (8) ISO 7042		
16	1x		System 2020A / 2040A		
17	1x		3120 A		
18	1x			0062	
19	1x			1012	
20	1x		100kg	1016	
21	2x				

(E) Volumen de suministro del enganche

(D) Lieferumfang der Anhängervorrichtung

(GB) Scope of delivery of towing hitch

(F) Pièces comprises dans la fourniture de l'attelage

(NL) Leveringsomvang trekhaak

(S) Dragkrokens leveransspecifikation

(CZ) Objem dodání tažného zařízení

(I) Dotazione del gancio di traino

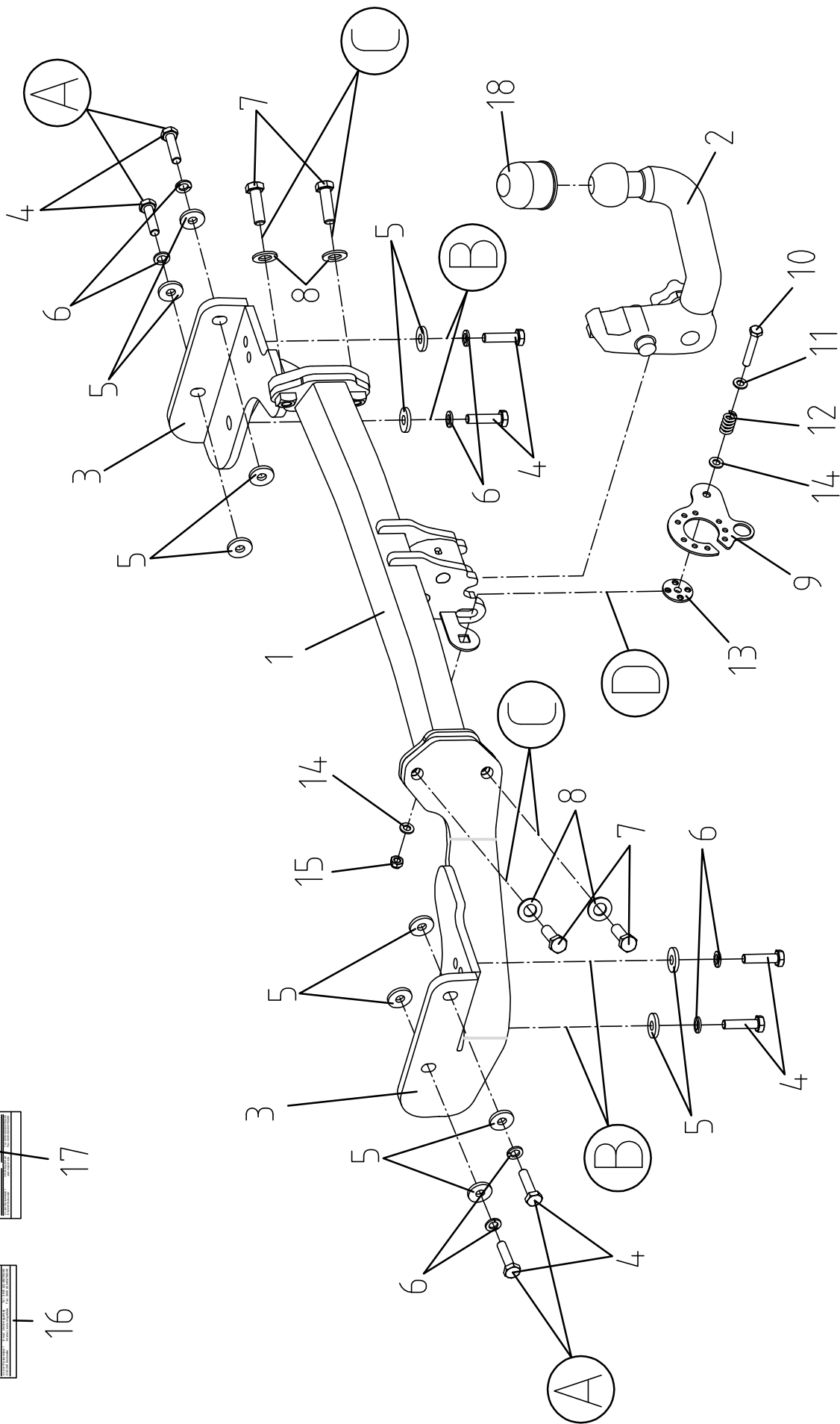
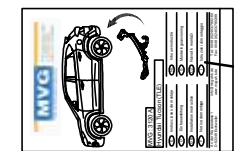
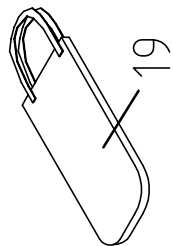
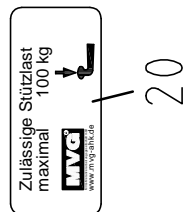

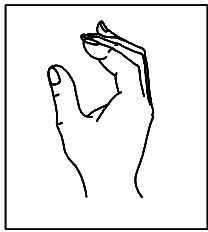
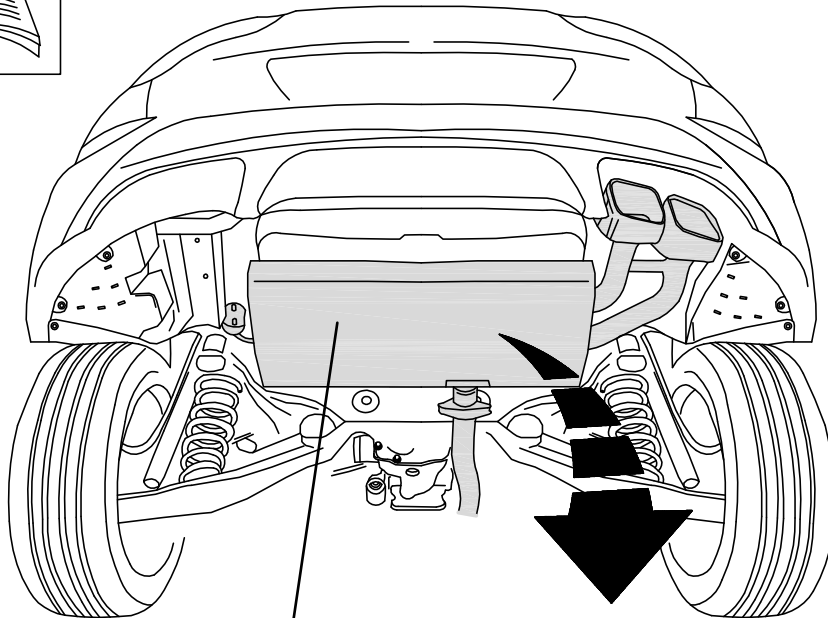
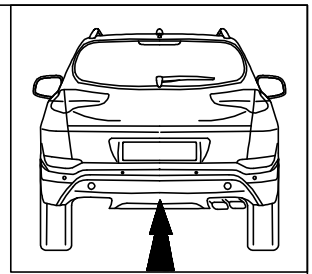
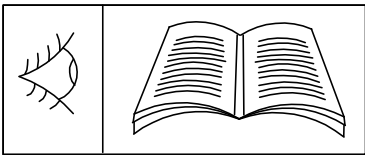

X1

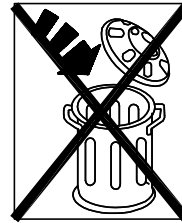

2

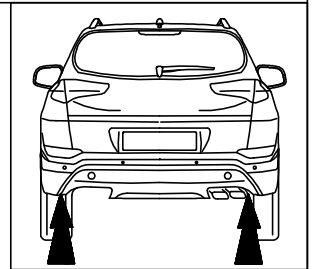
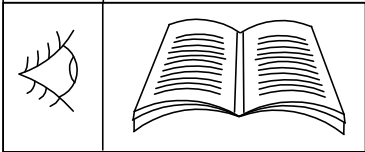

X2

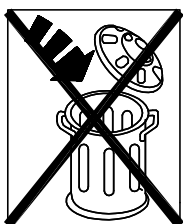
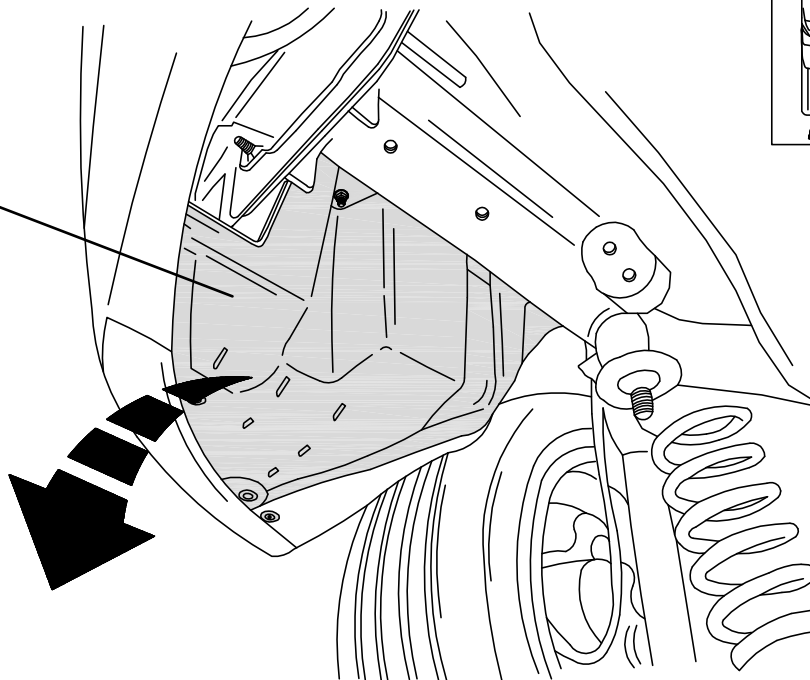

3

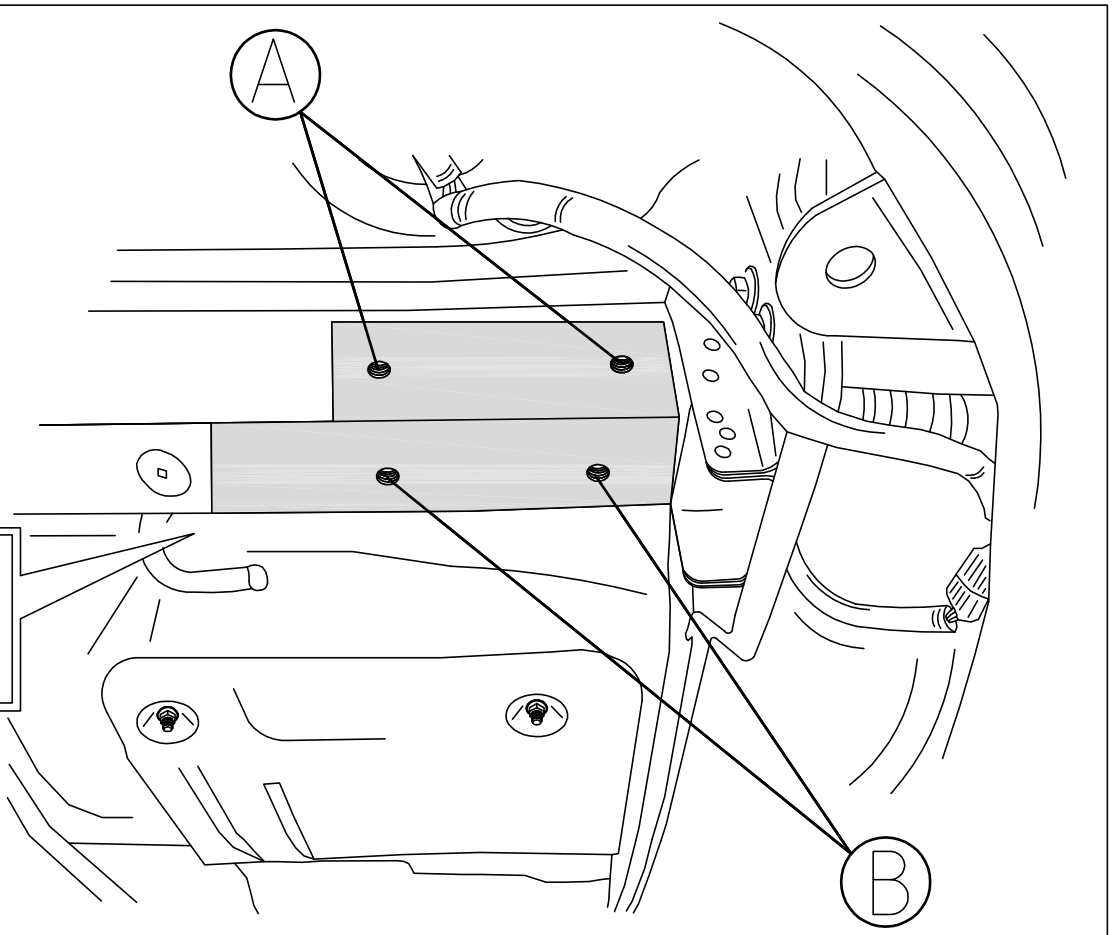
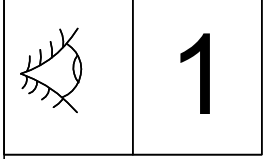
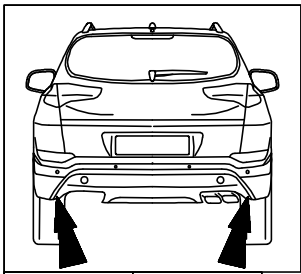

4

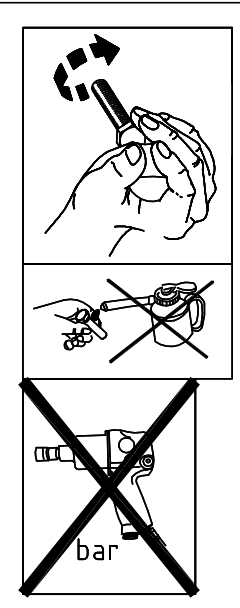
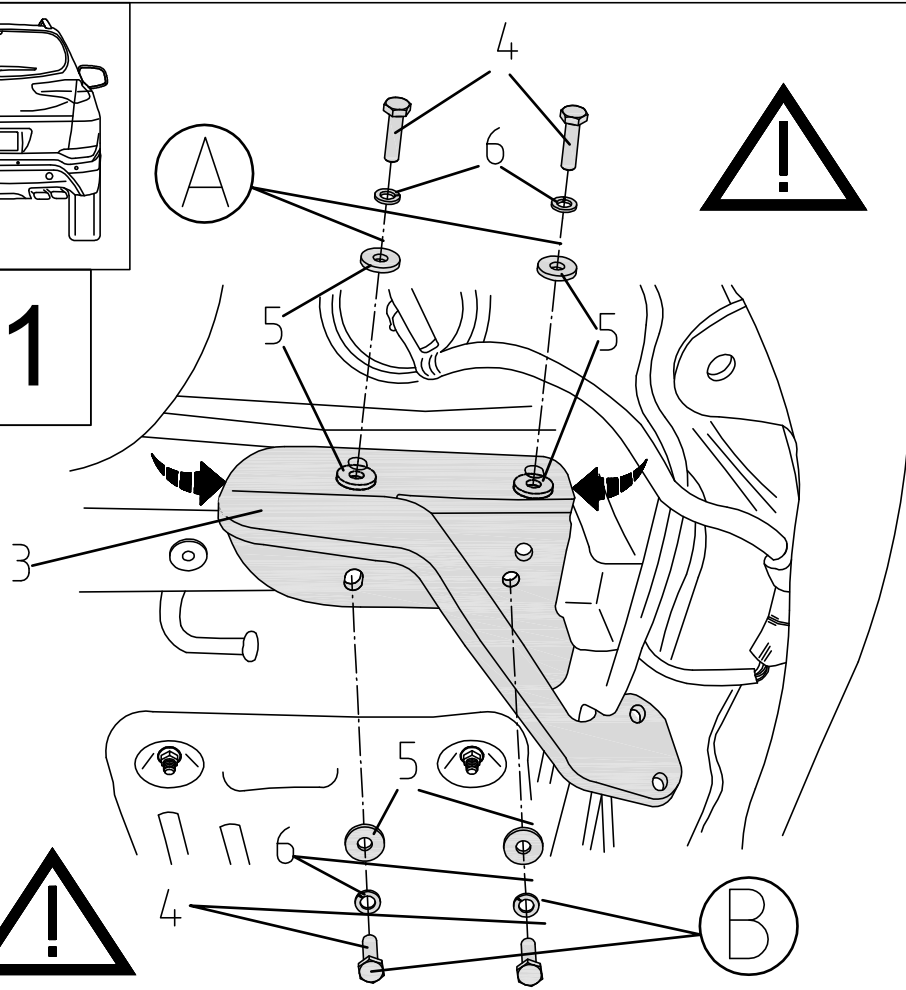
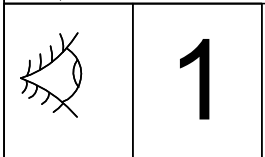
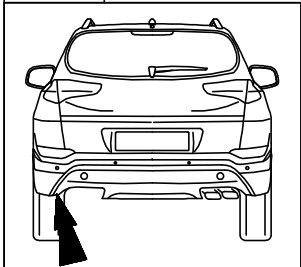

5



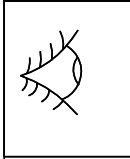
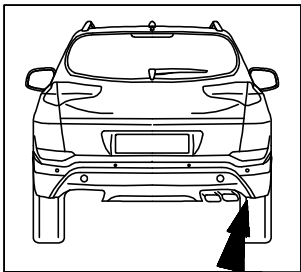

1

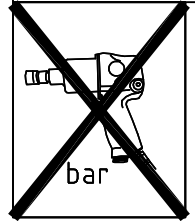
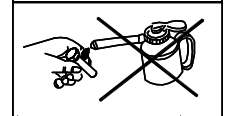
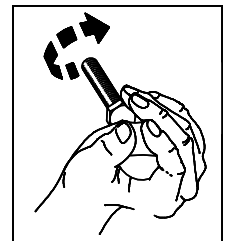
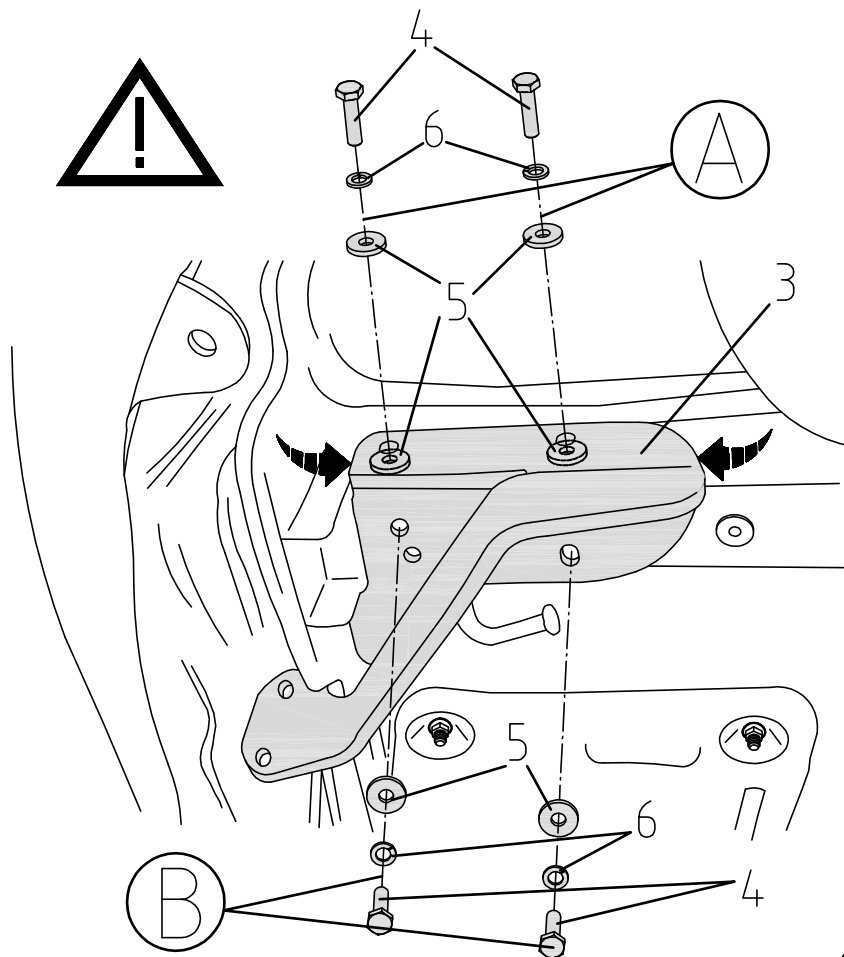

6

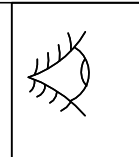
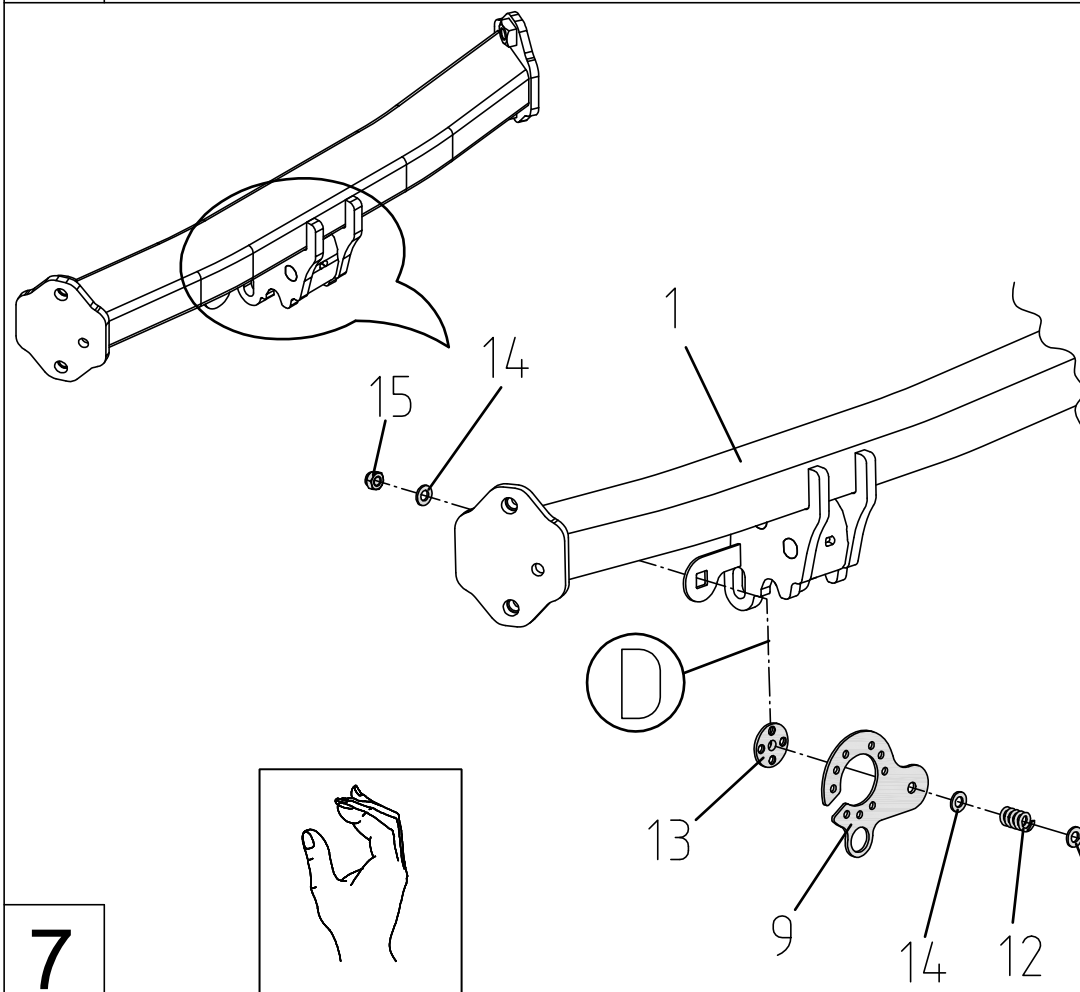

1

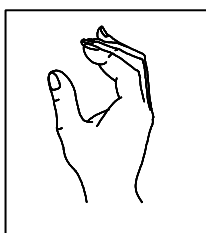
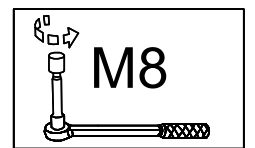

7

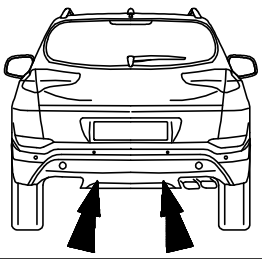

1

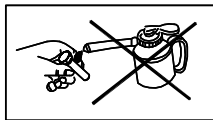
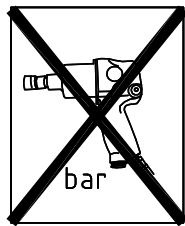
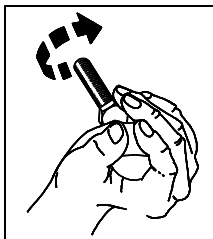
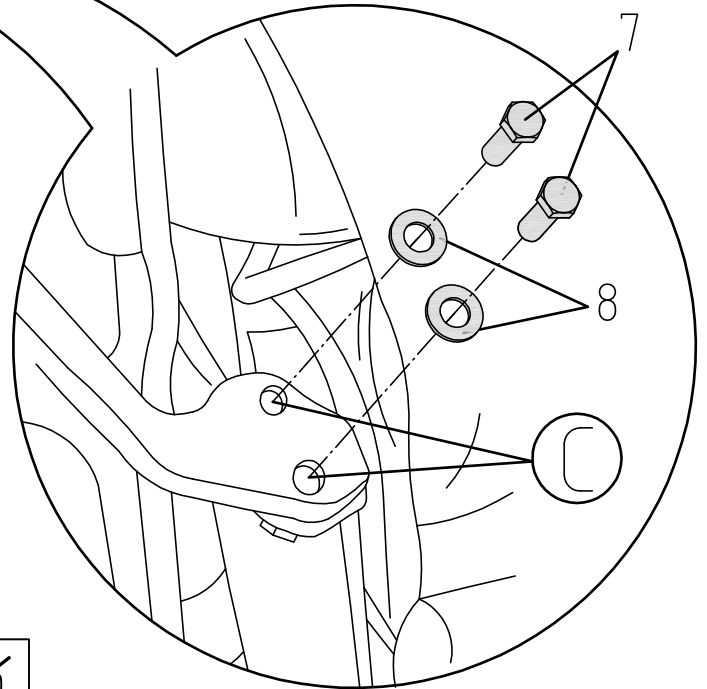
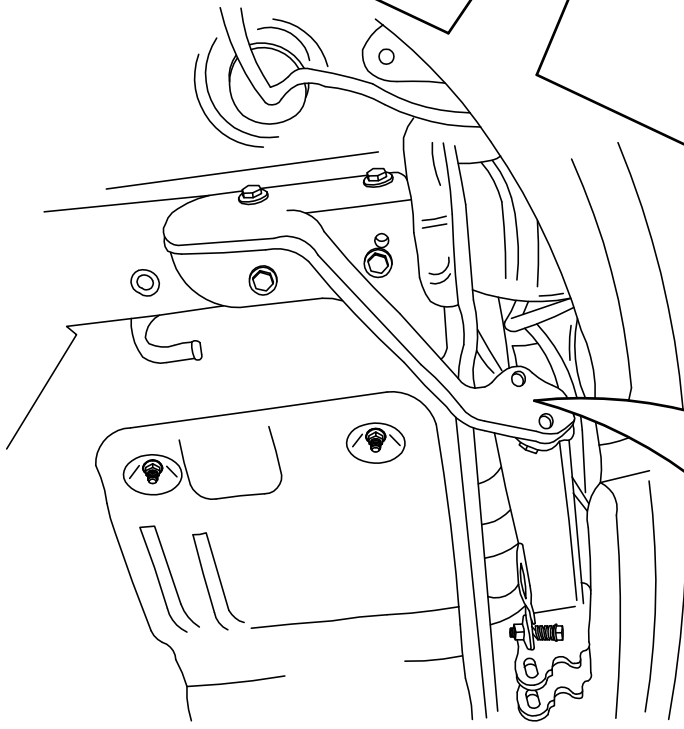
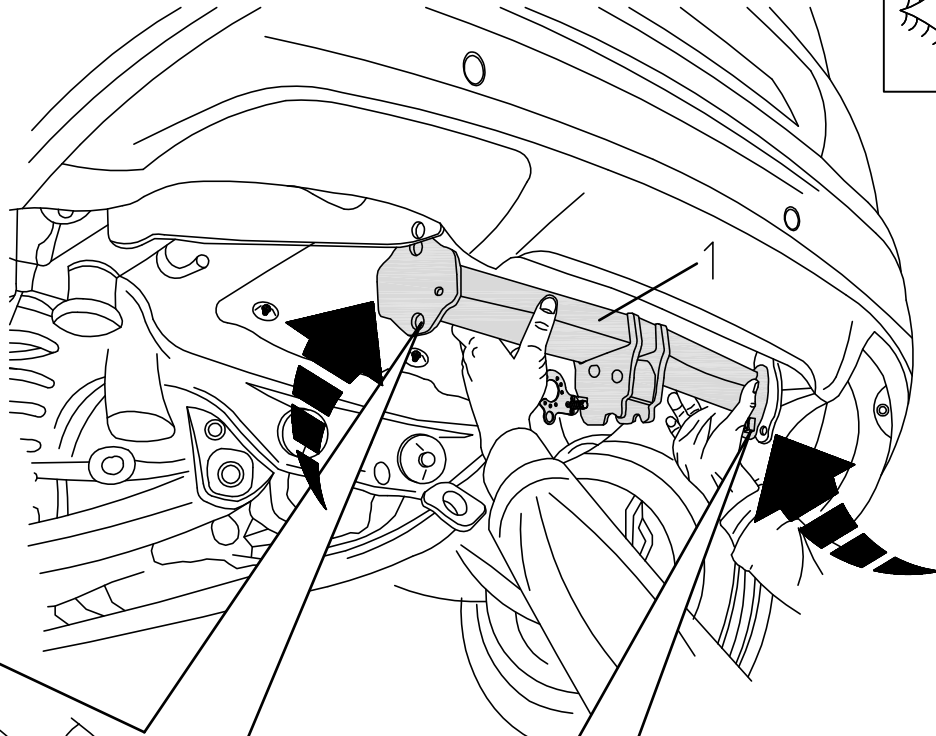

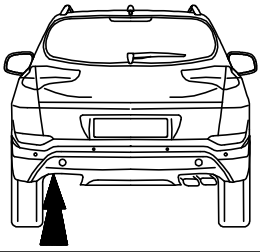

8

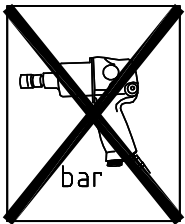
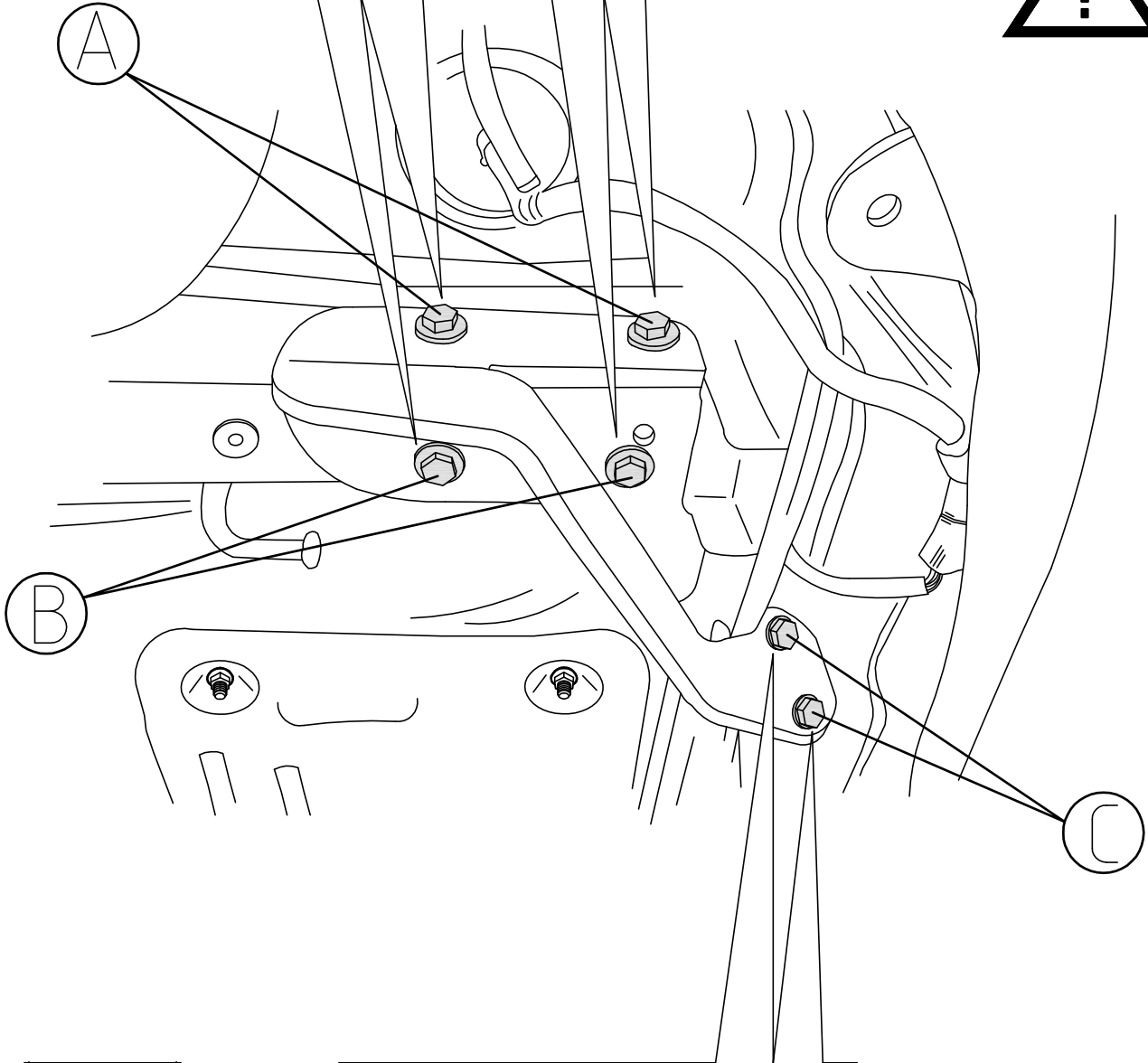

1

	M10x1,25	8.8	40 Nm
---	----------	-----	-------



	M12	8.8	68 Nm
---	-----	-----	-------



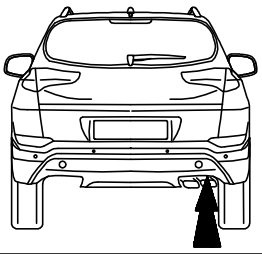

9

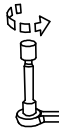

1

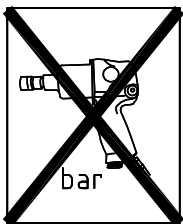
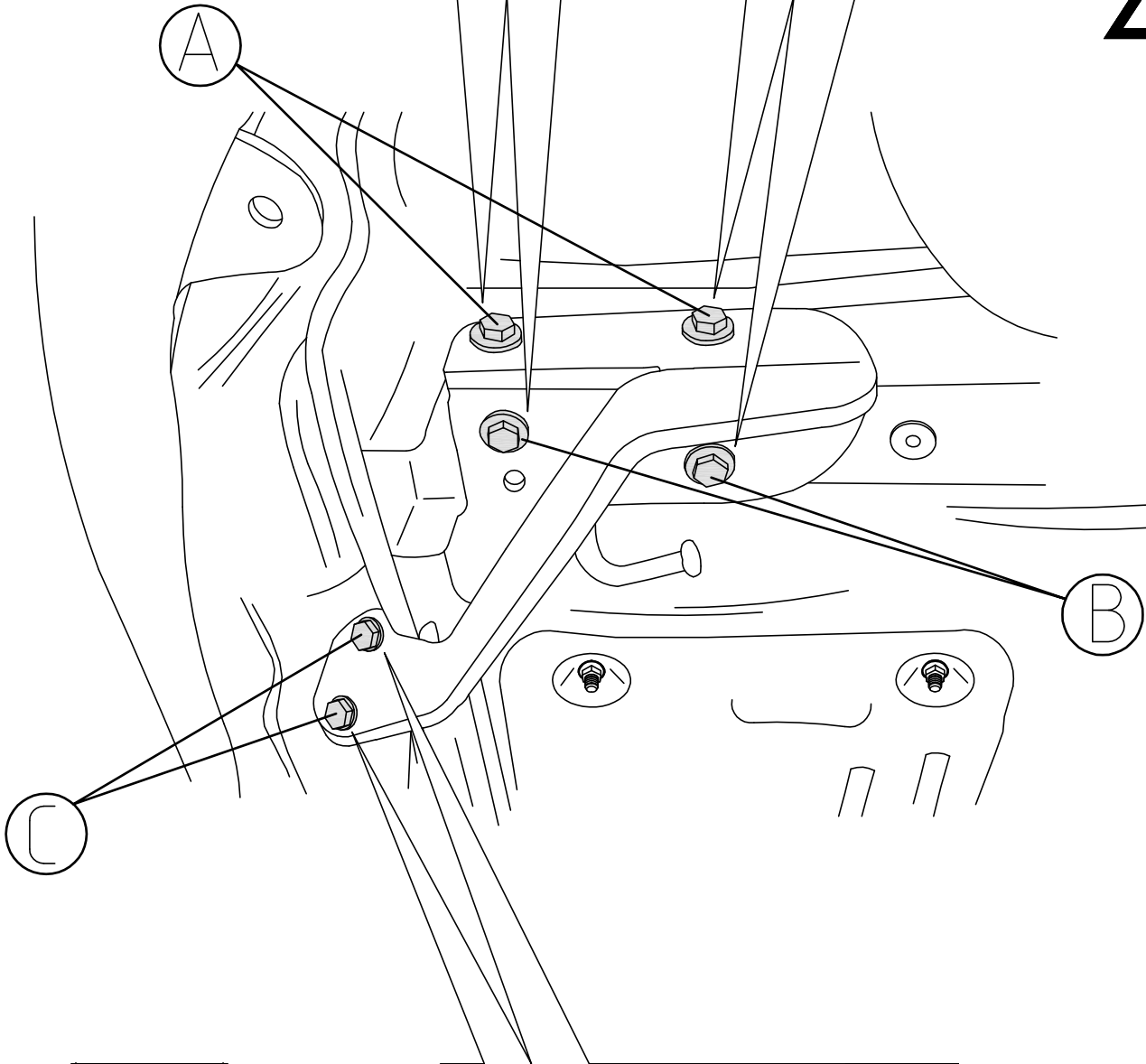
	M10x1,25	8.8	40 Nm
---	----------	-----	-------



	M12	8.8	68 Nm
---	-----	-----	-------

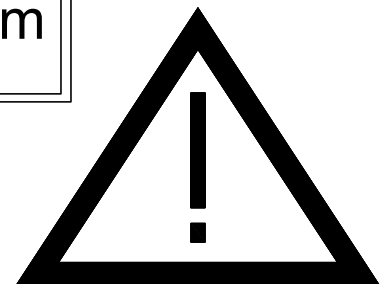

10

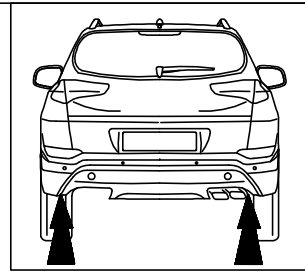
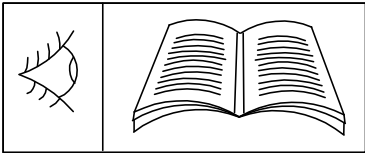

X2

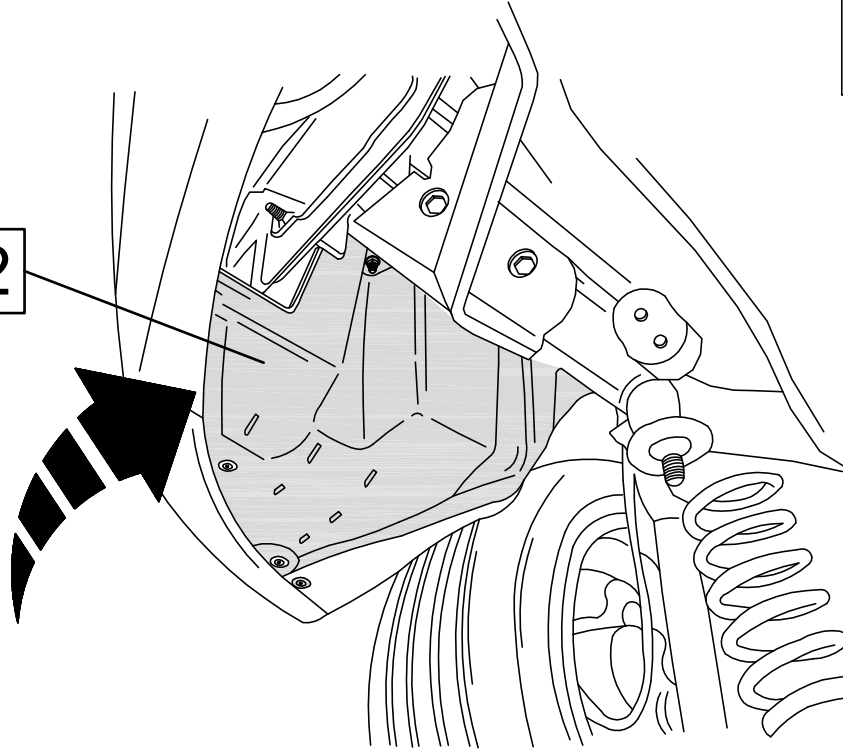

11

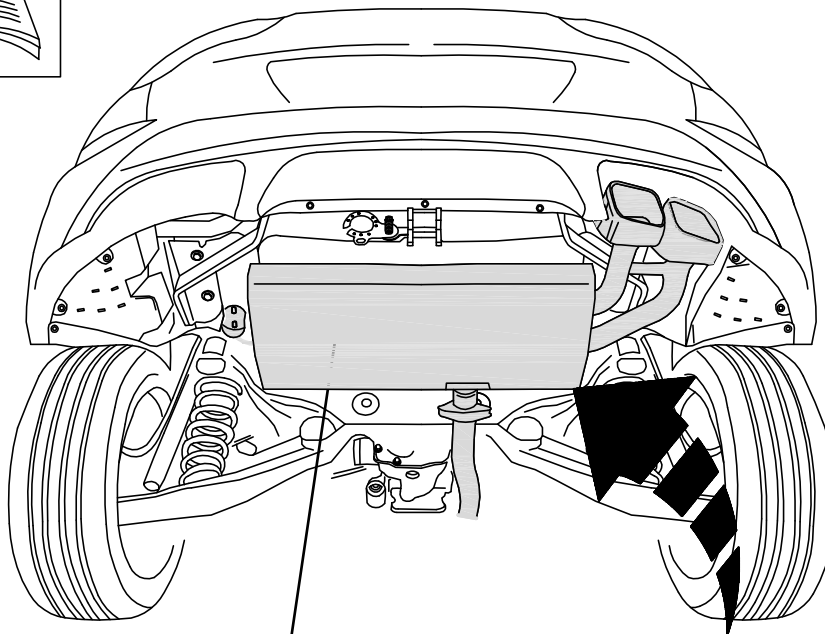
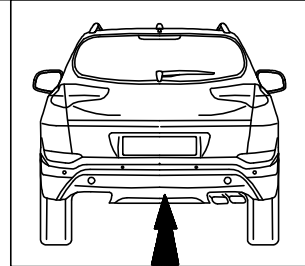
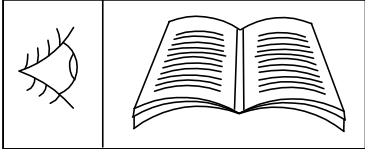

X1

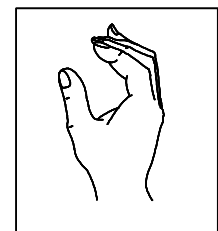

12

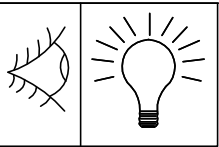

Zulässige Stützlast maximal 100 kg
MVG
www.mvg-ahk.de



20

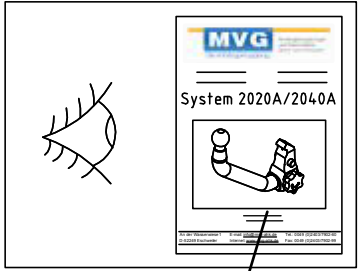
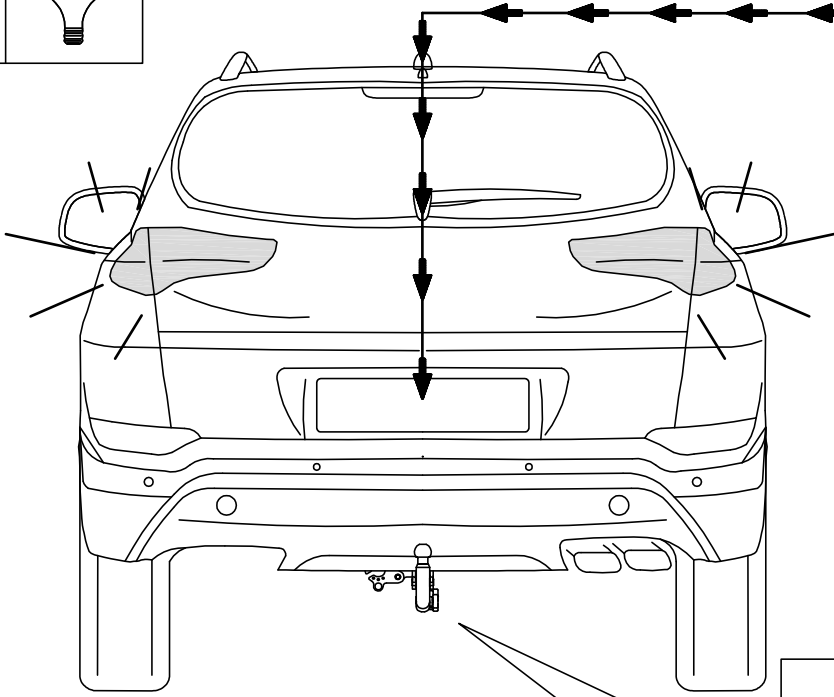

16

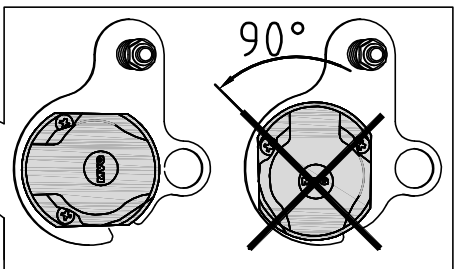

13

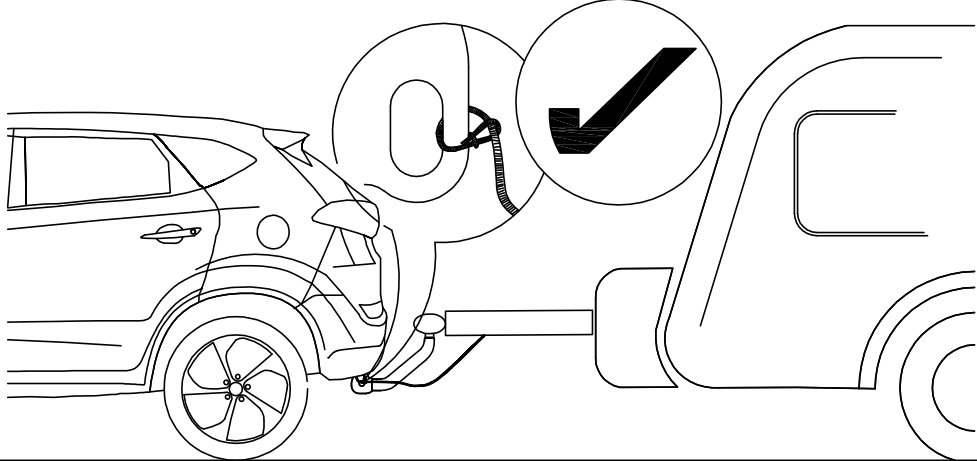
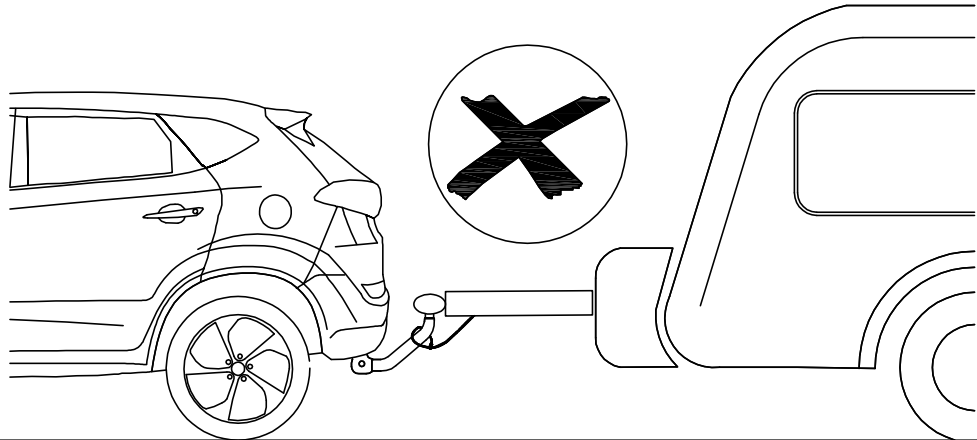

14

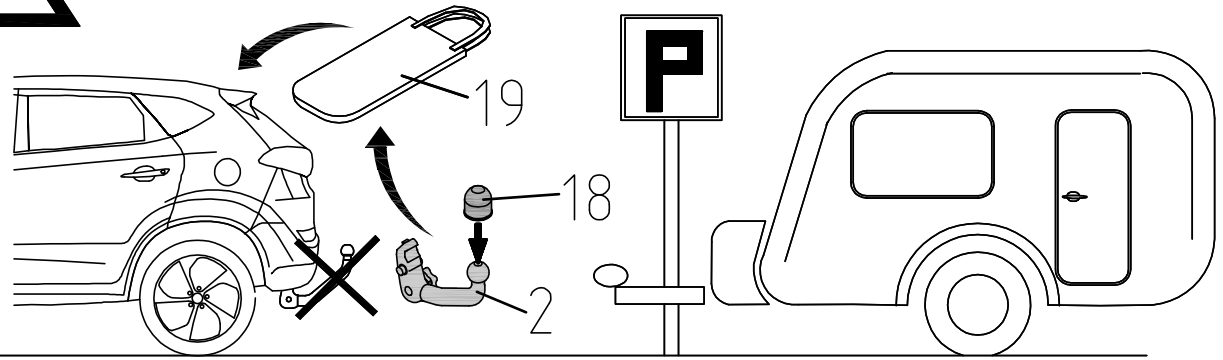
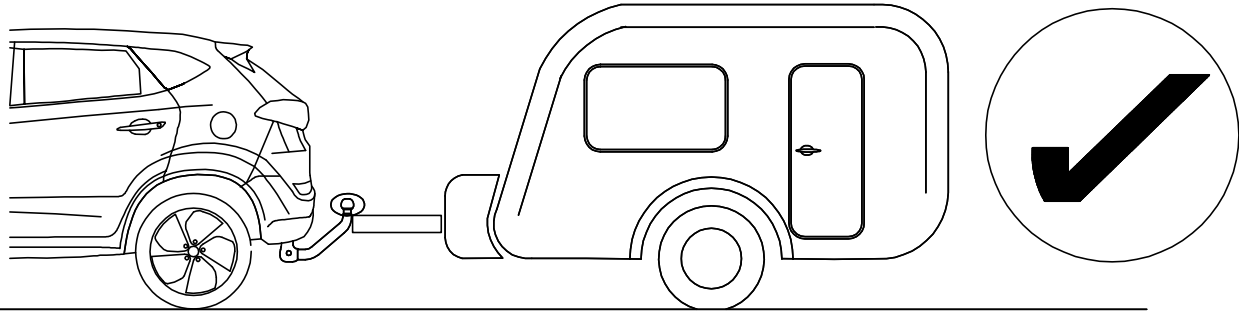

15

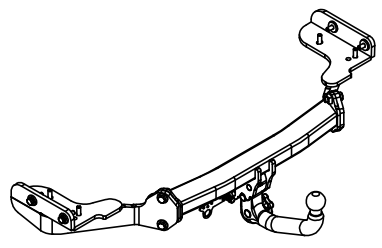
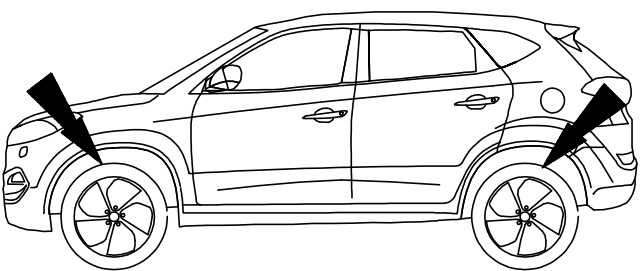

Best. Nr.: 3120 A

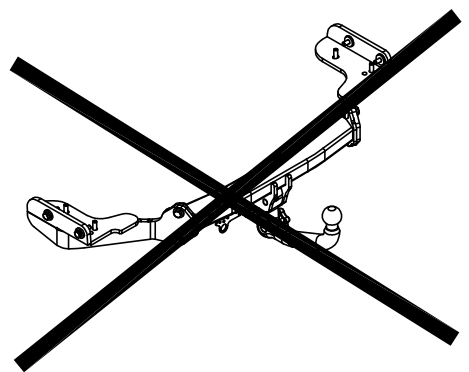
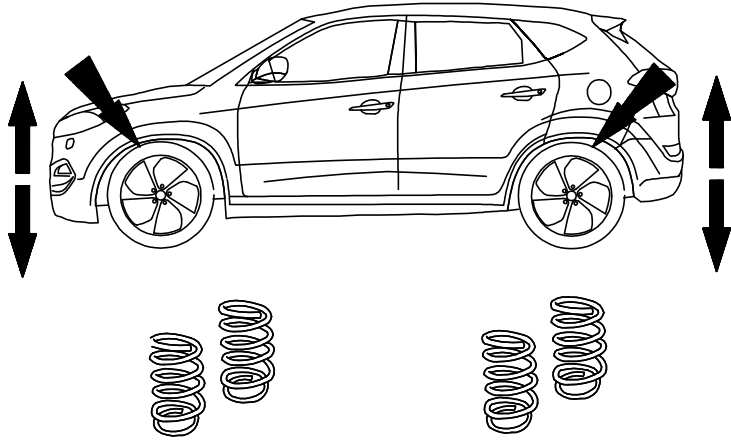

16

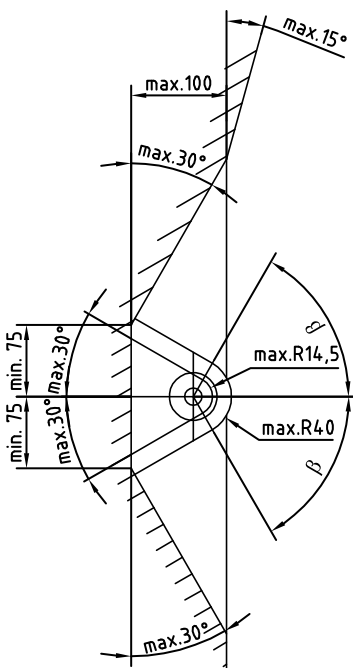
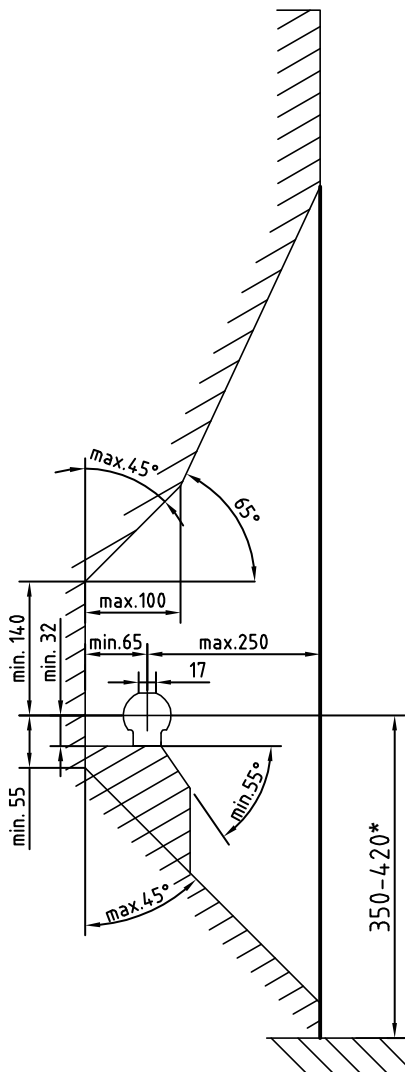

- D** Der Freiraum nach Anhang 7, Abbildung 25a und 25b der Richtlinie ECE-R 55 ist zu gewährleisten.
- CZ** Volný prostor ve smyslu Přílohy 7, obr. 25a a 25b směrnice ECE-R 55 musí být zaručen.
- DK** Det skal sikres, at der er spillerum i overensstemmelse med bilag 7, fig. 25a og 25b i henhold til direktiv ECE-R 55.
- E** Hay que garantizar el espacio libre conforme al anexo 7, fig. 25a y 25b de la directiva ECE-R 55.
- F** La zone de dégagement, selon l'annexe 7, figure 25a et 25b de la directive ECE-R 55, doit être assurée.
- FIN** Välyksen tulee täyttää ohjeen ECE-R 55 liitteen 7 kuvissa 25a ja 25b ilmoitetut vaatimukset.
- GB** Make sure to provide clearance according to appendix 7, figures 25a and 25b of the ECE-R 55 regulations.
- GR** Πρέπει να εξασφαλίζεται ο ελεύθερος χώρος σύμφωνα με το παράρτημα 7, σχήμα 25a και 25b της κοινοτικής οδηγίας ECE-R 55.
- H** Biztosítani kell az ECE-R 55 irányelv szerinti, 7. számú függelék, 25a. és 25b ábrákban jelölt szabad teret.
- I** Deve essere garantito lo spazio libero secondo l'allegato 7, figure 25a e 25b della normativa europea ECE-R 55.
- N** Det må sørges for fritt rom i samsvar med tillegg 7, figur 25a og 25b i direktiv ECE-R 55.
- NL** De vrije ruimte volgens supplement 7, afbeelding 25a en 25b van richtlijn ECE-R 55 moet gewaarborgd zijn.
- PL** Należy zapewnić wolną przestrzeń zgodnie z załącznikiem 7, rys. 25a i 25b, dyrektywy ECE-R 55.
- RUS** Оставлять свободное пространство согласно Приложению 7, рис. 25a и 25b Директивы ECE-R 55.
- S** Spelrummet enligt bilaga 7, bild 25a och 25b i riktlinje ECE-R 55, måste garanteras.

- D** * bei zulässigem Gesamtgewicht des Fahrzeuges
- CZ** * při celkové přípustné hmotnosti vozidla
- DK** * ved tilladt totalvægt for køretøjet
- E** * con peso total autorizado del vehículo
- F** * pour poids total en charge autorisé du véhicule
- FIN** * Ajoneuvon suurimmalla sallitulla kokonaispainolla
- GB** * at gross vehicle weight rating
- GR** * για το επιτρεπτό μικτό βάρος του οχήματος
- H** * A jármű megengedett összsúlya esetén
- I** * per il peso complessivo ammesso del veicolo
- N** * ved kjøretøyets tillatte totalvekt
- NL** * bij toegestaan totaal gewicht van het voertuig
- PL** * przy dopuszczalnym ciężarze całkowitym pojazdu
- RUS** * при допустимом общем весе автомобиля
- S** * vid fordonets tillåtna totalvikt

- D** Die Anhängervorrichtung ist ein Sicherheitsteil und darf nur von Fachunternehmen montiert werden. Bei falscher Montage besteht schwere Unfallgefahr! Der deutsche Text dieser Anleitung ist bindend.
- CZ** Tažné zařízení je bezpečnostní součást, kterou smí montovat pouze odborné podniky. Při chybné montáži hrozí vážné nebezpečí nehody! Německý text tohoto návodu je závazný.
- DK** Anhængertrækket er en sikkerhedsdel og må kun monteres af autoriserede firmaer. Ved forkert montering er der fare for alvorlige uheld! Den tyske tekst i denne vejledning er bindende.
- E** La bola de enganche es un elemento de seguridad y sólo se debe permitir su montaje a personal cualificado. ¡En caso de montaje erróneo existe peligro de accidentes graves! Es vinculante el texto alemán de estas instrucciones.
- F** Le dispositif d'attelage est un équipement de sécurité et doit être mis en place exclusivement par un atelier spécialisé. Un montage incorrect représente un risque élevé d'accident! Le texte allemand de cette notice fait foi.
- FIN** Vetolaite on turvallisuuteen vaikuttava osa, jonka saa asentaa vain alan erikoisliike. Virheellinen asennus voi aiheuttaa vakavan onnettomuuden! Tämän ohjeen saksankielinen teksti on sitova.
- GB** A trailer hitch is a safety-critical part and may be fitted only by qualified companies. Improper assembly may result in a serious accident hazard! The German text of this instruction is binding.
- GR** Ο κοσμοδόρος είναι ένα εξάρτημα ασφαλείας και η τοποθέτηση του επιτρέπεται να γίνεται μόνο από εξειδικευμένο συνεργείο. Σε περίπτωση λάθους τοποθέτησης υπάρχει κίνδυνος σοβαρών ατυχημάτων! Το γερμανικό κείμενο αυτών των οδηγιών είναι δεσμευτικό.
- H** A vonószerkezet egy biztonsági felszerelés, amelyet csak szaküzem szerelhet fel. Helytelen szerelés súlyos balesethez vezethet! A német szerelési utasítás betartása kötelező.
- I** Il gancio di traino è un componente di sicurezza e deve essere montato esclusivamente da personale specializzato. In caso di montaggio errato sussiste il pericolo di incidenti gravi! È vincolante il testo tedesco di queste istruzioni.
- N** Tilhengerfestet er en sikkerhetskompoment og skal monteres av fagbedrift. Det er stor fare for at det kan oppstå ulykker ved feil montering! Den tyske teksten i denne veiledningen er bindende.
- NL** De aanhanger is veiligheidsonderdeel en mag alleen door vakkundig personeel worden gemonteerd. Bij verkeerde montage bestaat ernstig gevaar voor ongevallen! De Duitse tekst van deze handleiding is bindend.
- PL** Hak holowniczy stanowi element bezpieczeństwa i może zostać zamontowany wyłącznie przez firmę specjalistyczną. W przypadku nieprawidłowego montażu istnieje poważne ryzyko wypadku! Tekst niniejszej instrukcji w języku niemieckim jest wiążący.
- RUS** Сцепное устройство - это узел, несущий предохранительные функции, и к его монтажу допускаются только специалисты. При неправильном монтаже грозит опасность тяжелых травм! Обязательным является немецкий текст данной инструкции.
- S** Dragkroken är en säkerhetskompoment och bör endast monteras av kvalificerade tekniker. Vid felaktig montering föreligger risk för allvarliga olyckor! Den tyska texten i denna anvisning är bindande.