

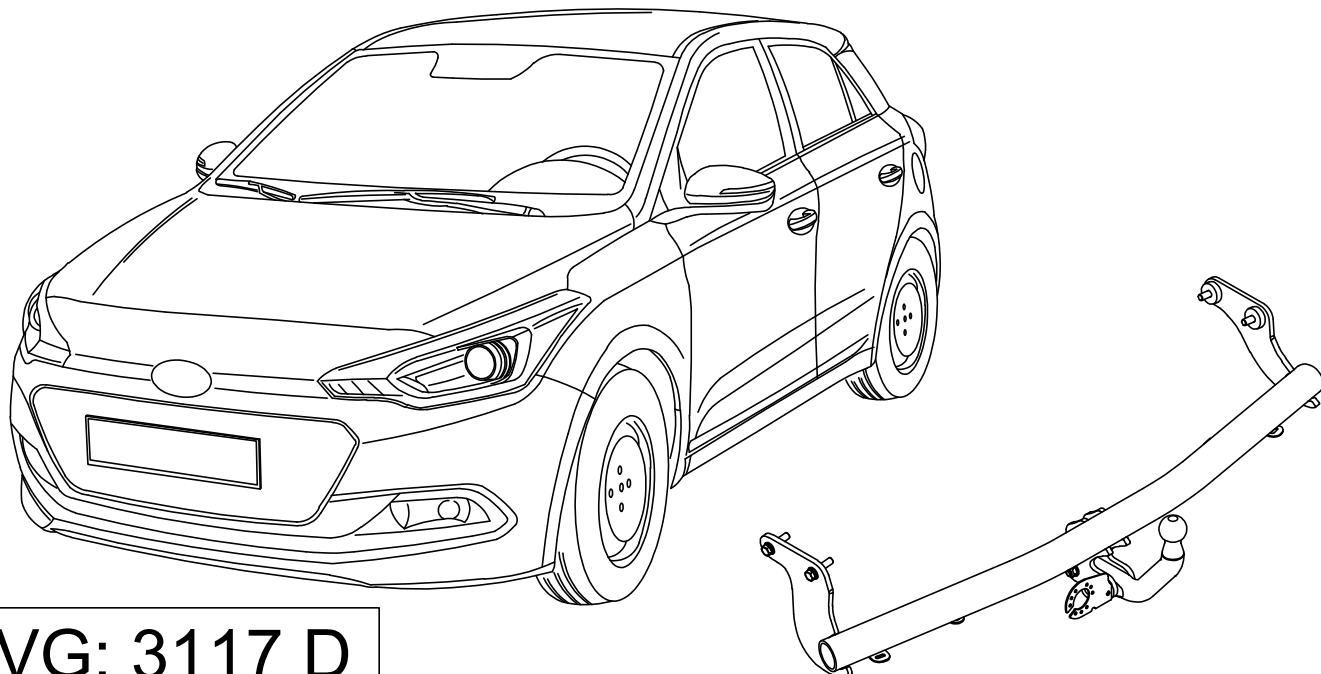

Die Anhängerkupplung.

Anhängerkupplungen
und Elektrosätze direkt
vom Hersteller



MVG: 3117 D

Hyundai i20 & i20 FL 2018 (5 Tüerer)

Hyundai i20 Coupé (3 Tüerer bis 2018)

Hyundai i20 Active (GB)

~~Hyundai i20 Active FL 2018~~

~~Hyundai i20 ab Mj 2020~~

E Instrucciones de montaje

NL Inbouw instructie

D Einbauanleitung

S Monteringsanvisning

GB Installation instruction

CZ Návod k montáži

F Notice de montage

I Istruzioni di montaggio

An der Wasserwiese 1
D-52249 Eschweiler

info@mvg-ahk.de
www.mvg-ahk.de

Tel.: 0049 (0)2403/7902-60
Fax: 0049 (0)2403/7902-99

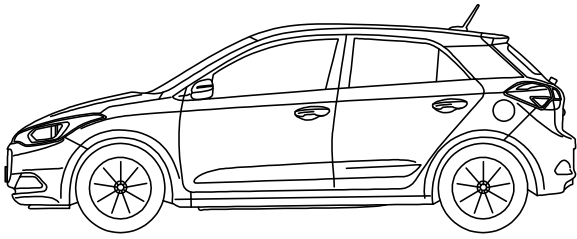

↓ ≤ 1690 kg



EG

e11 * 2007/46 * 1600

$$D = 6,8 \text{ kN}$$

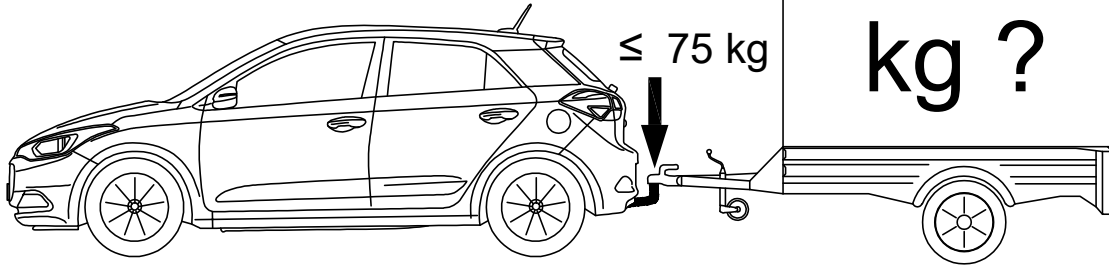

$$D = \frac{T \times R}{1000 \times (T + R)} \times g$$

$$g = 9,81 \text{ m/s}^2$$

$$T = \frac{R \times D \times 1000}{(g \times R) - (1000 \times D)}$$

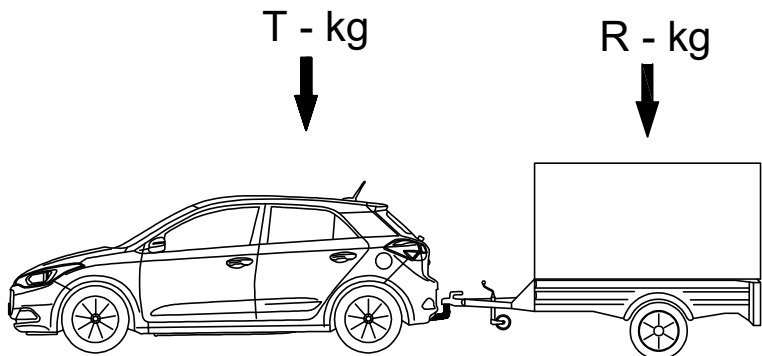

$$R = \frac{T \times D \times 1000}{(g \times T) - (1000 \times D)}$$

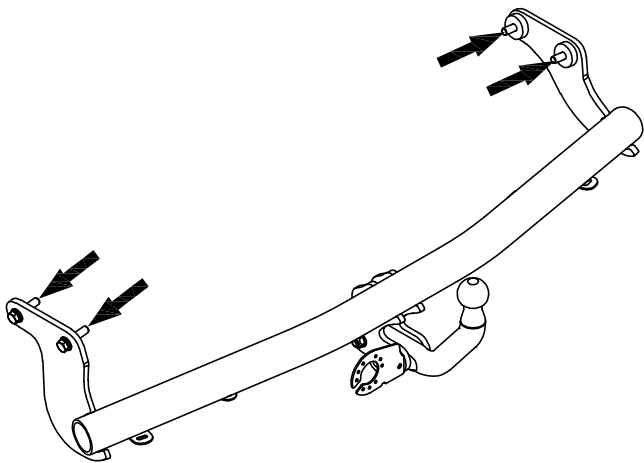
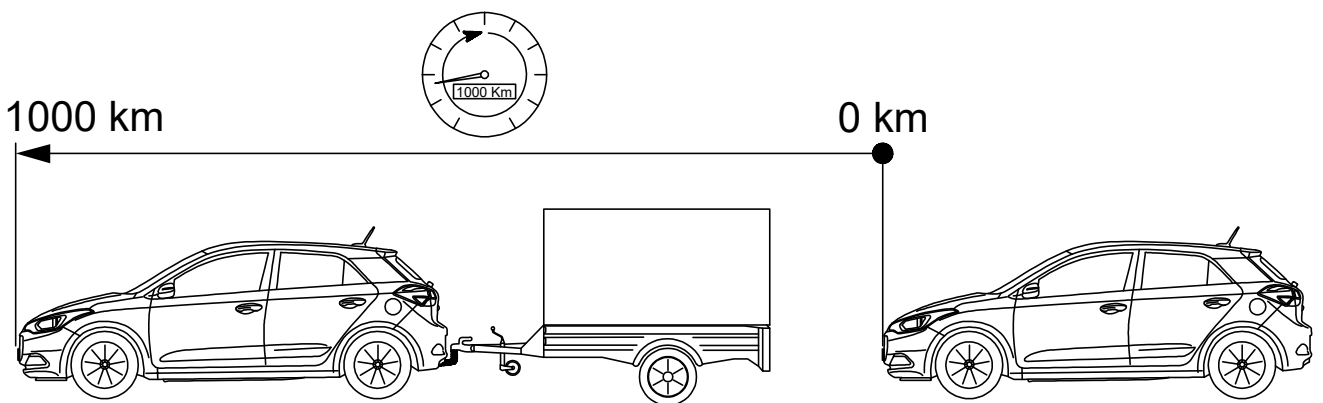
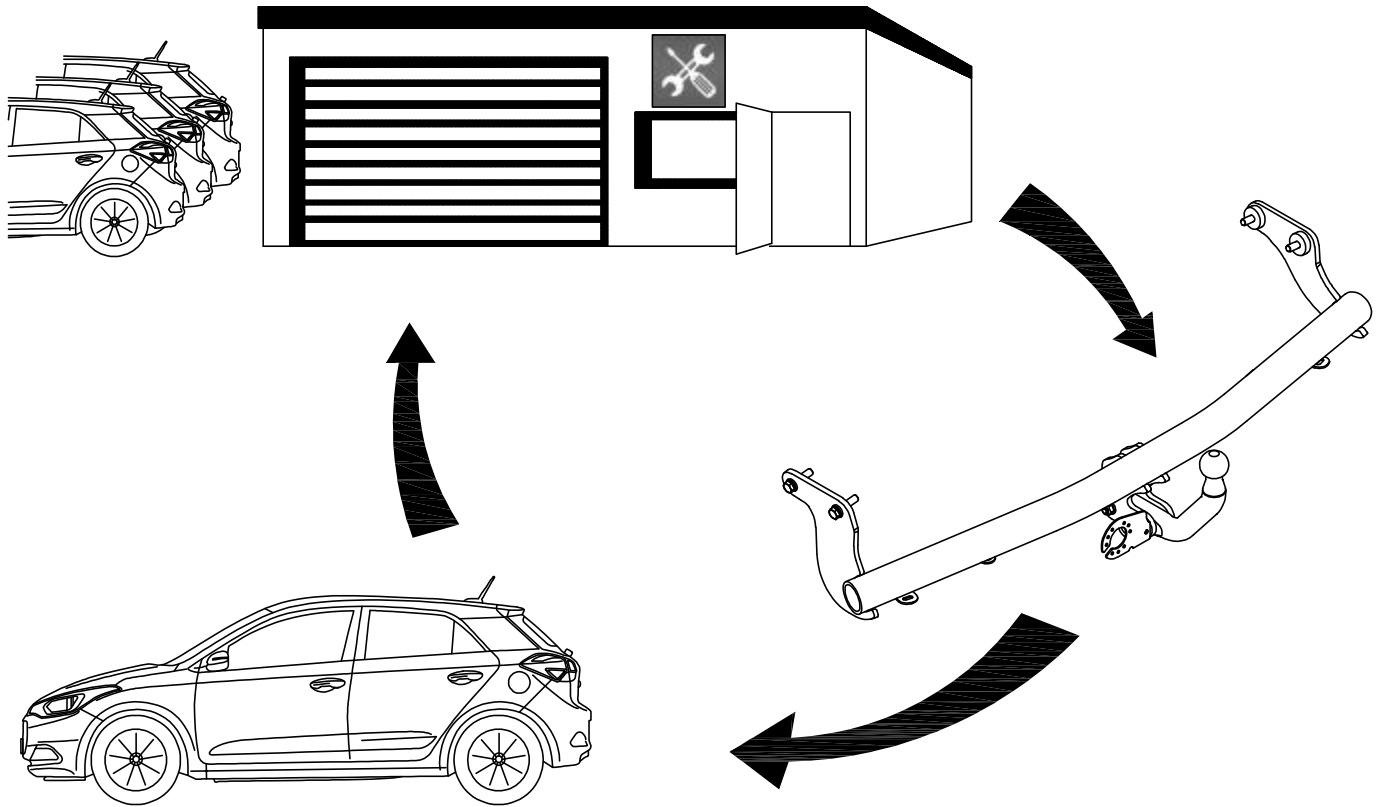

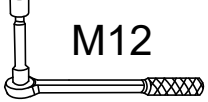
 M6	8 Nm
 M12	68 Nm
	100 Nm



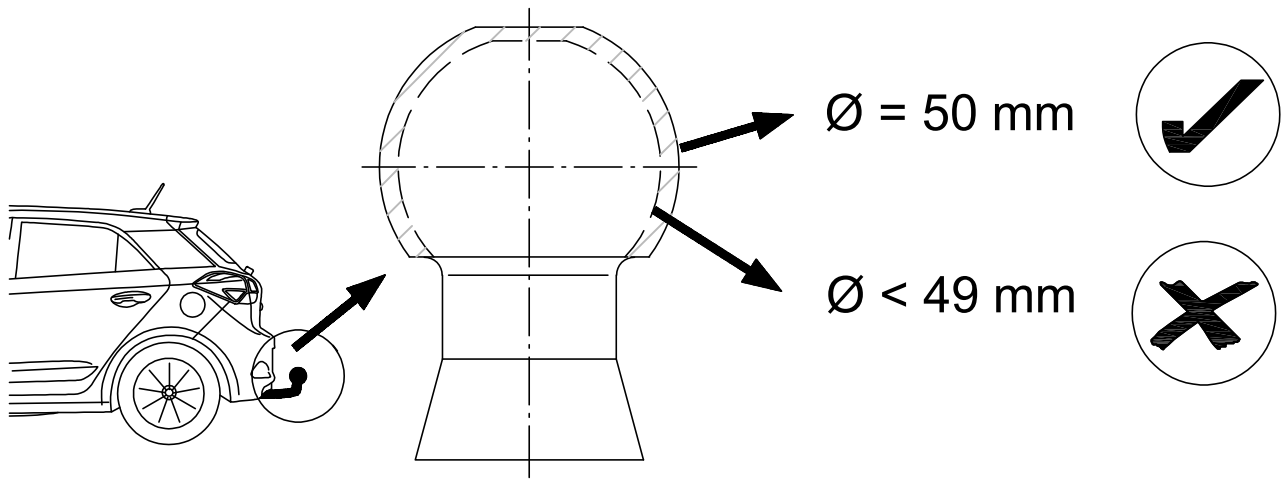

MVG[®] Approval Number
 MVG-Metalverarbeitungsgesellschaft mbH **E4** 55R-01 0531
 Type: 3117 D D-Value: 6,8 kN
 Class: A50-X S-Value: 80 kg
 Made in Germany www.mvg-ahk.de

Zulässige Stützlast
 maximal 75 kg

MVG[®]
 MVG-Metalverarbeitungsgesellschaft mbH
 www.mvg-ahk.de

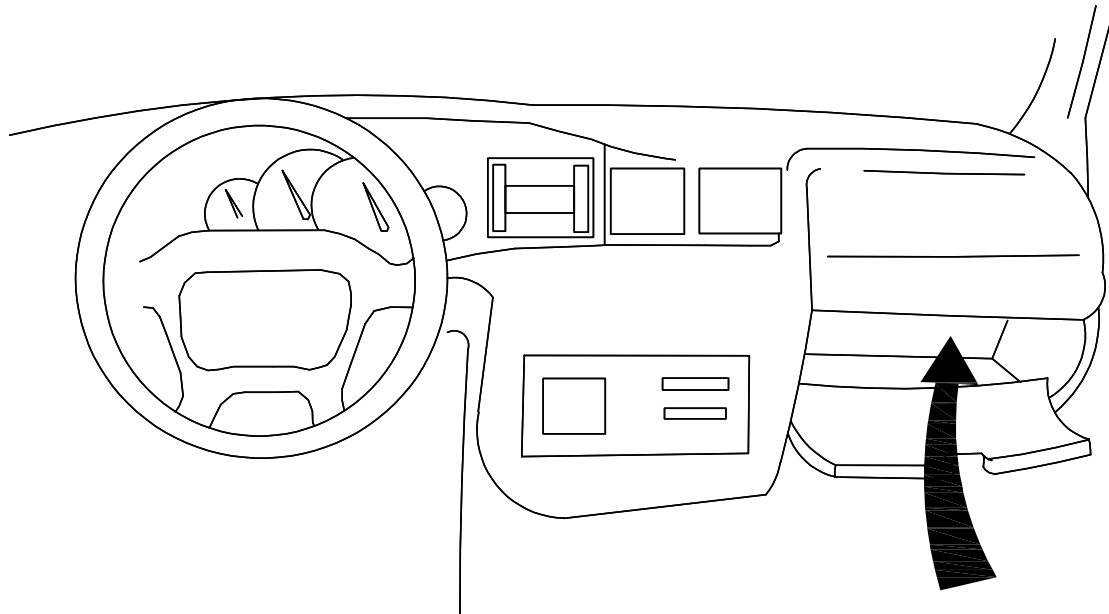





















Technische Änderungen vorbehalten

MVG[®]

MVG-3117 D
 Hyundai i20 & i20 FL 2018 (5 Türen)
 Hyundai i20 Coupe (3 Türen bis 2018)
 Hyundai i20 Active (GB)
 Hyundai i20 Active FL 2018
 Hyundai i20 ab Mj. 2020

○ Installation de montage	○ Réserve véhicule
○ Dimensionierung	○ Montageanleitung
○ Installation/contrôle	○ Réserve espace
○ Niveau de montage	○ Niveau de montage

© 2020 Metalverarbeitungsgesellschaft mbH
 www.mvg-ahk.de

1	1x		3117 D	
2	1x		2000-B-52.0	
3	2x		∅40x∅13x12	
4	2x			
5	2x		M12x1,25x50 (8.8) ISO 8676	
6	2x		M12x1,25x35 (8.8) ISO 8676	
7	4x		A12 Fst. DIN 127	
8	5x		∅ 13/24x2.5 ISO 7089	
9	1x			
10	2x		M12x70 (10.9) ISO 4014	
11	2x		M12 (10) ISO 7042	
12	2x		M6x20 (8.8) ISO 4017	
13	2x		M6x30 (8.8) ISO 4017	
14	2x		∅ 6,4/12x1.6 ISO 7089	
15	4x		∅ 6,4/18x1.6 ISO 7093	
16	2x		M6 (8) ISO 7042	
17	2x		∅8,4/24x2 ISO 7093	
18	2x		∅ 25/8x10	
19	1x		0062	
20	1x		75 kg. 1016	
21	1x		3117 D	

- (E) Volumen de suministro del enganche
- (D) Lieferumfang der Anhängervorrichtung
- (GB) Scope of delivery of towing hitch
- (F) Pièces comprises dans la fourniture de l'attelage
- (NL) Leveringsomvang trekhaak
- (S) Dragkrokens leveransspecifikation
- (CZ) Objem dodání tažného zařízení
- (I) Dotazione del gancio di traino

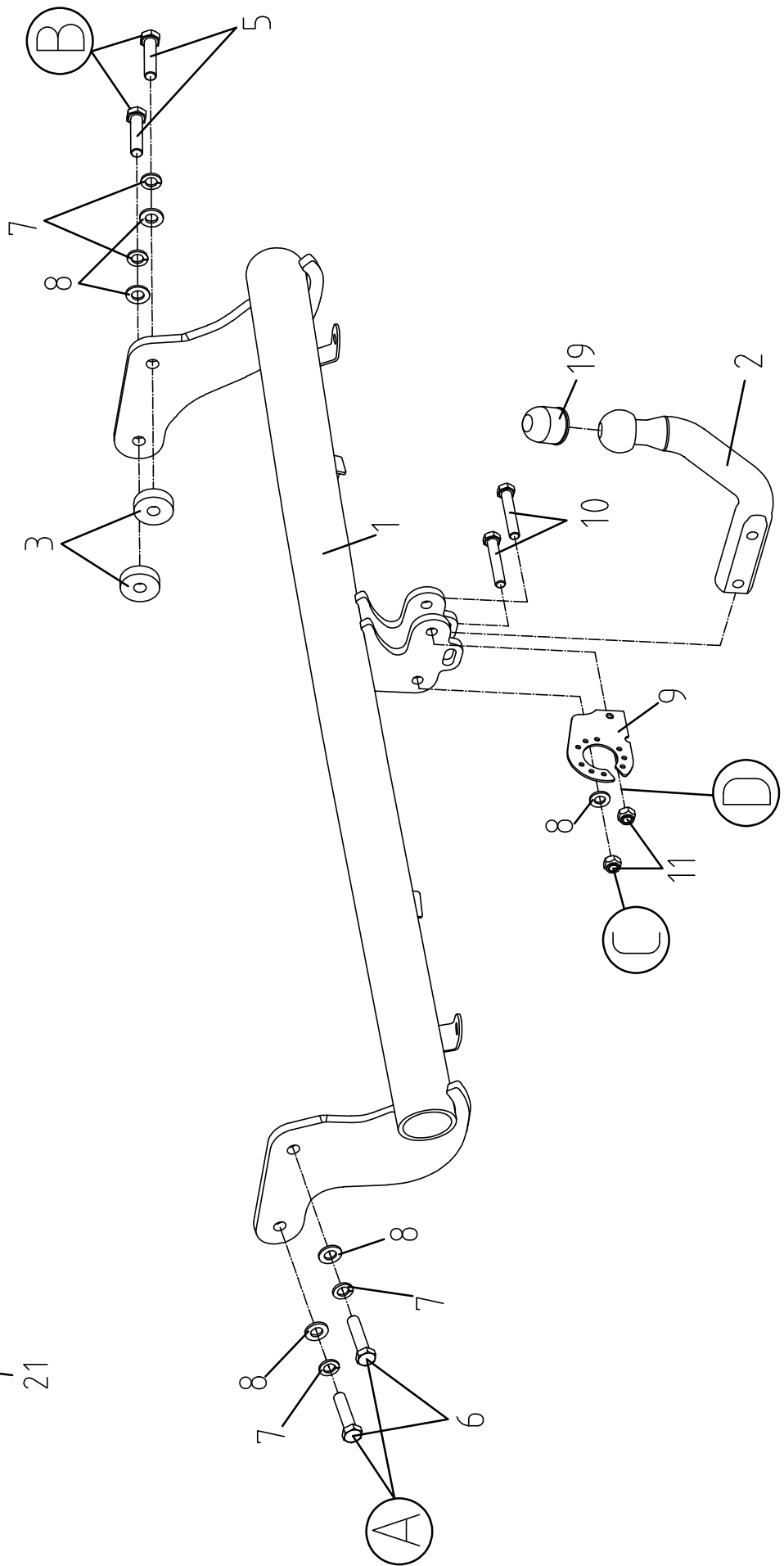
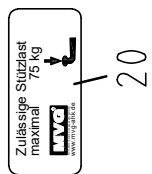
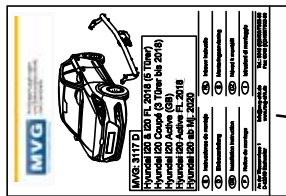

(E) Hyundai i20

(F) Hyundai i20 FL 2018
& i20 Coupé

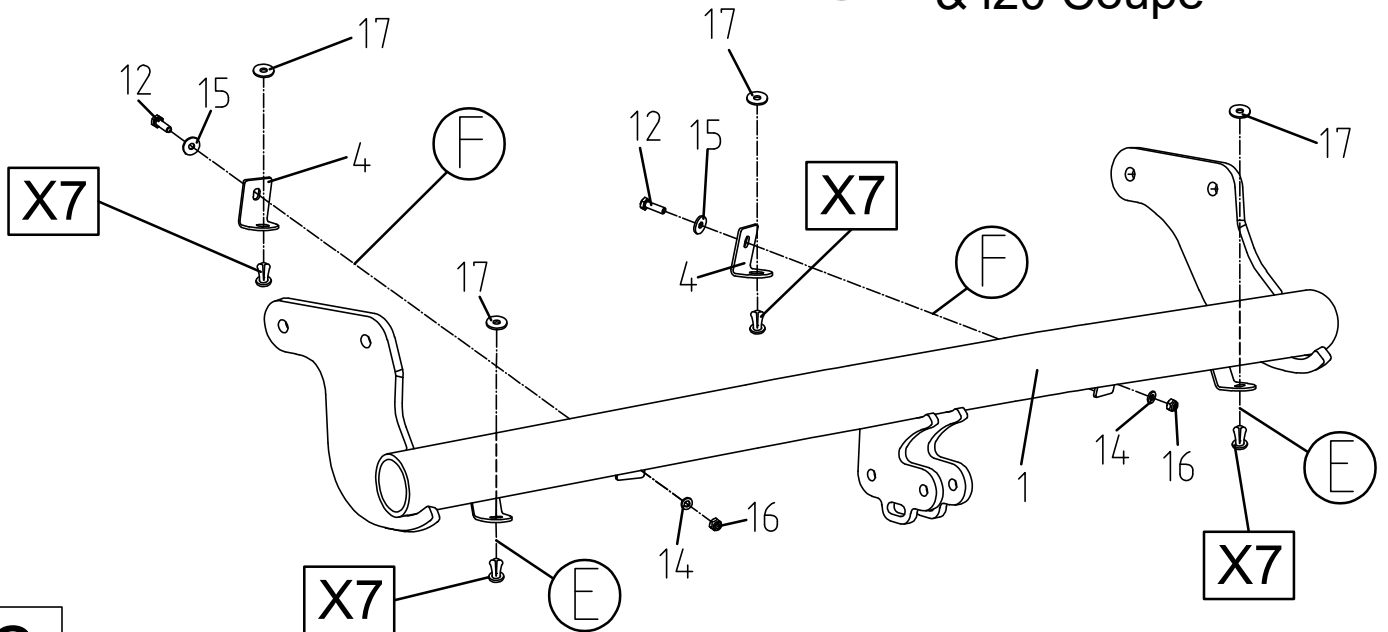

2

(G) Hyundai i20
Active

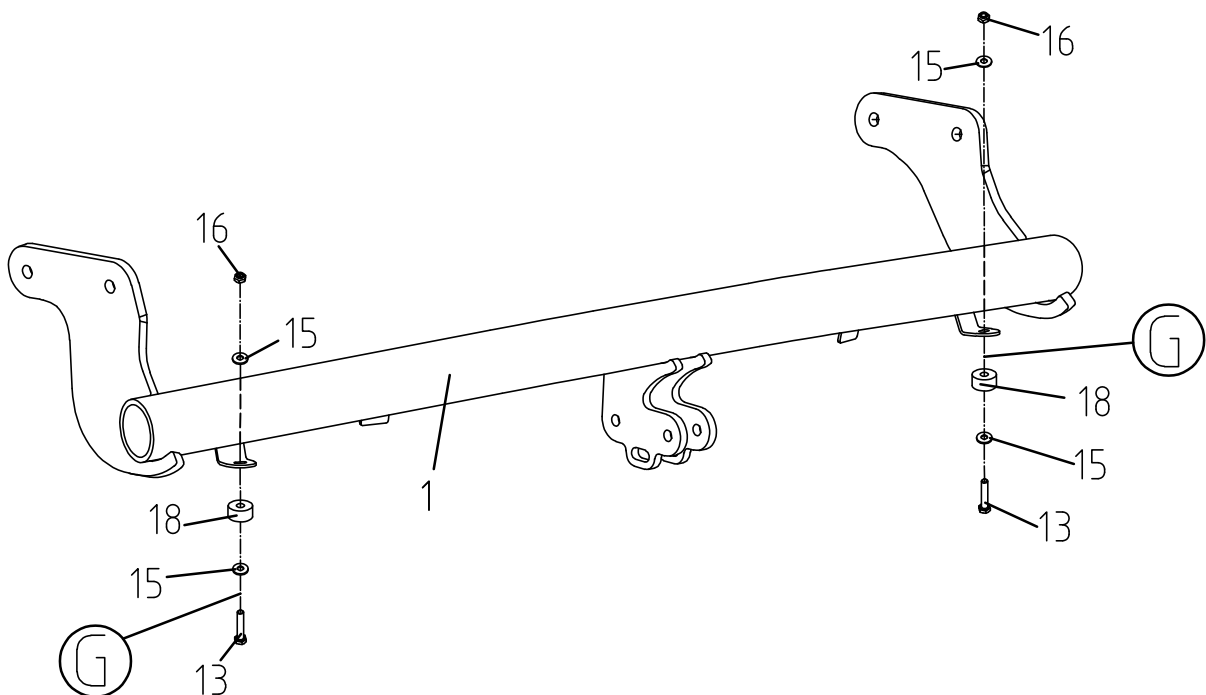

3

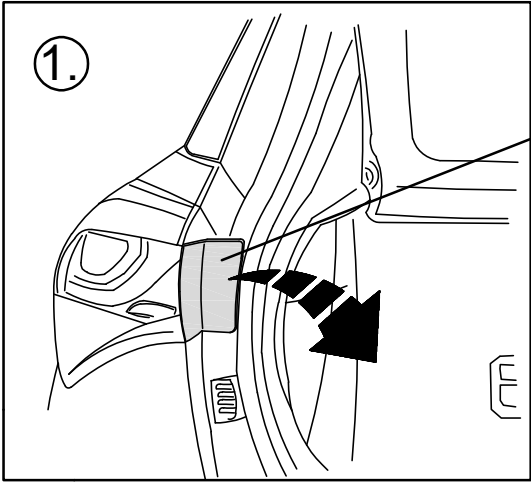
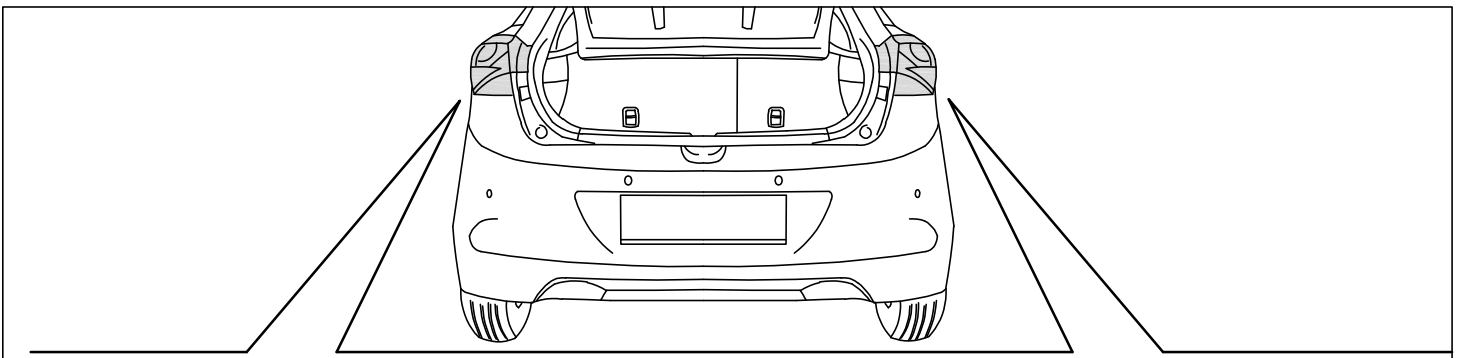

X1

X2

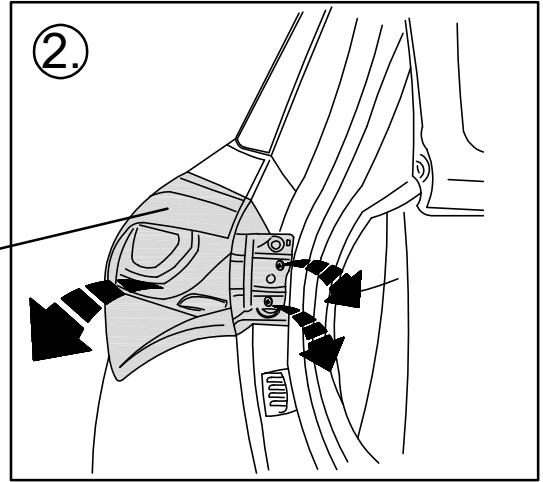

4

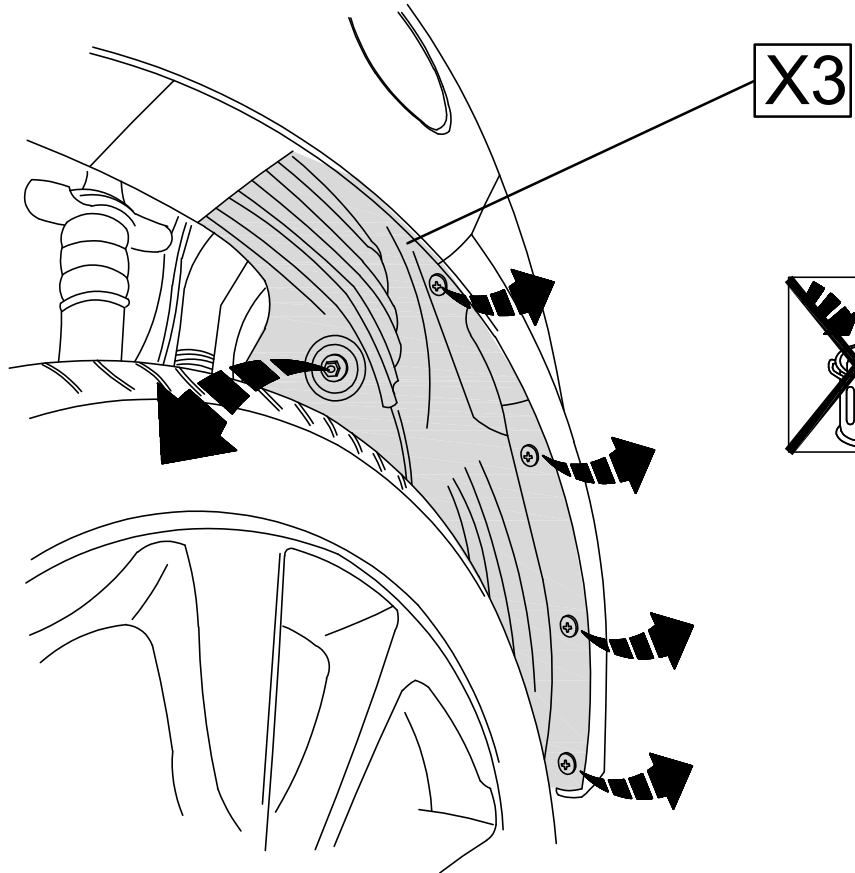
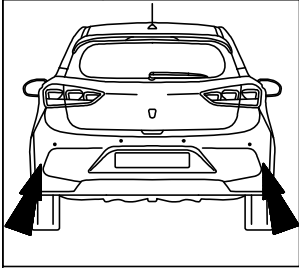

5

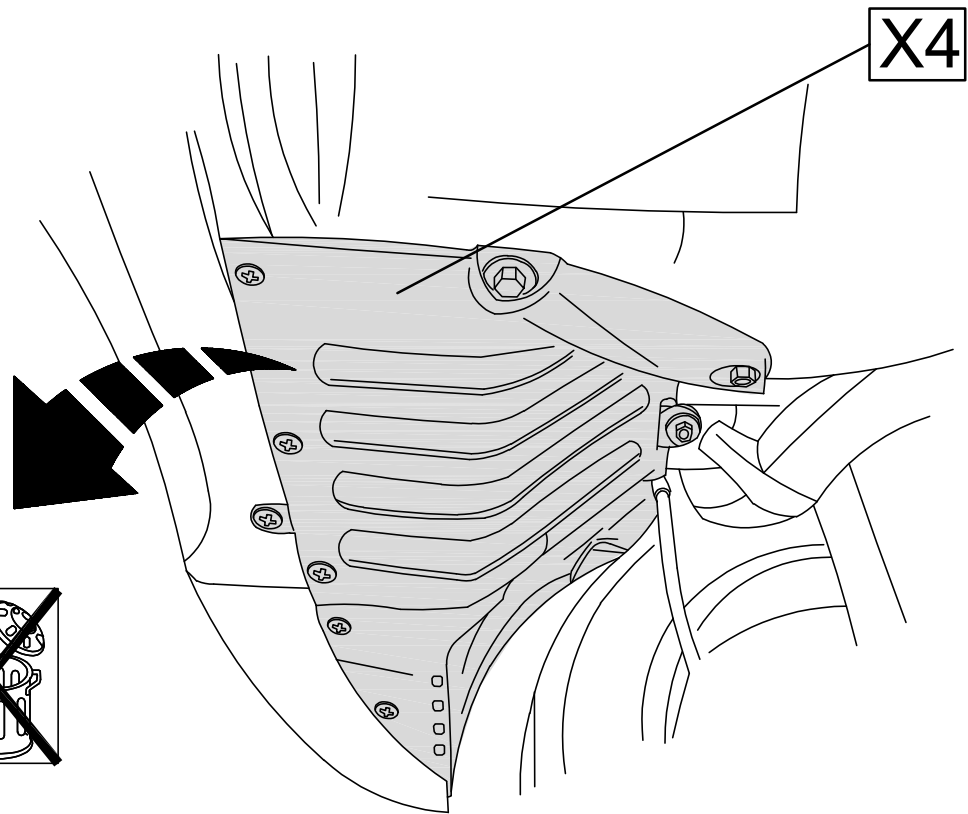
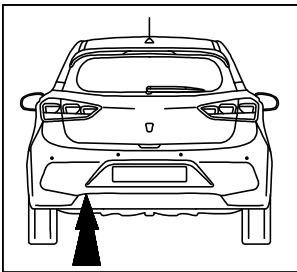

6

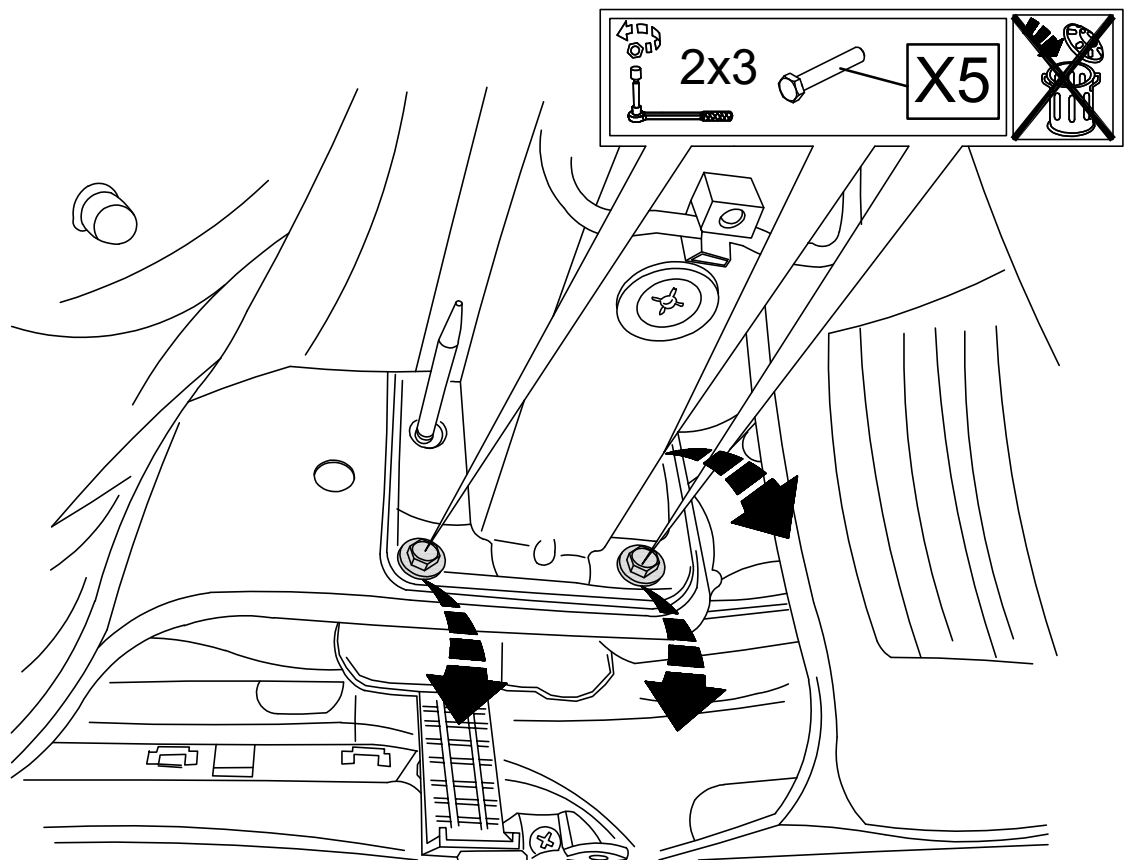
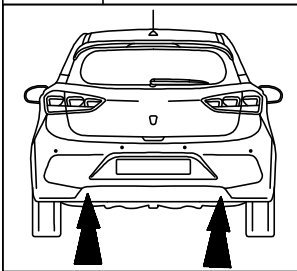

7

X6

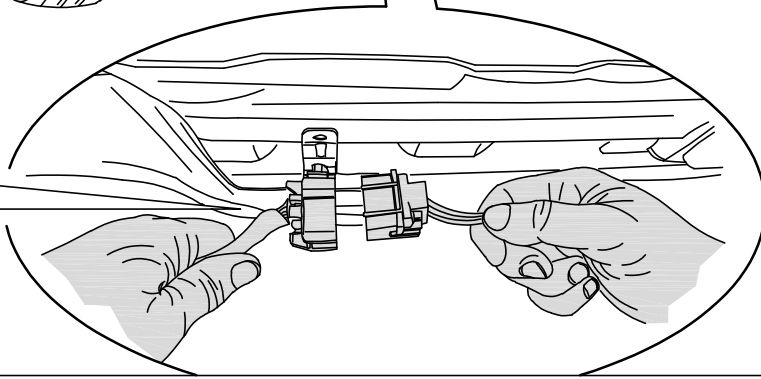
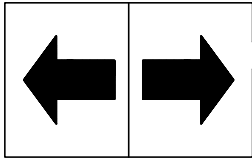
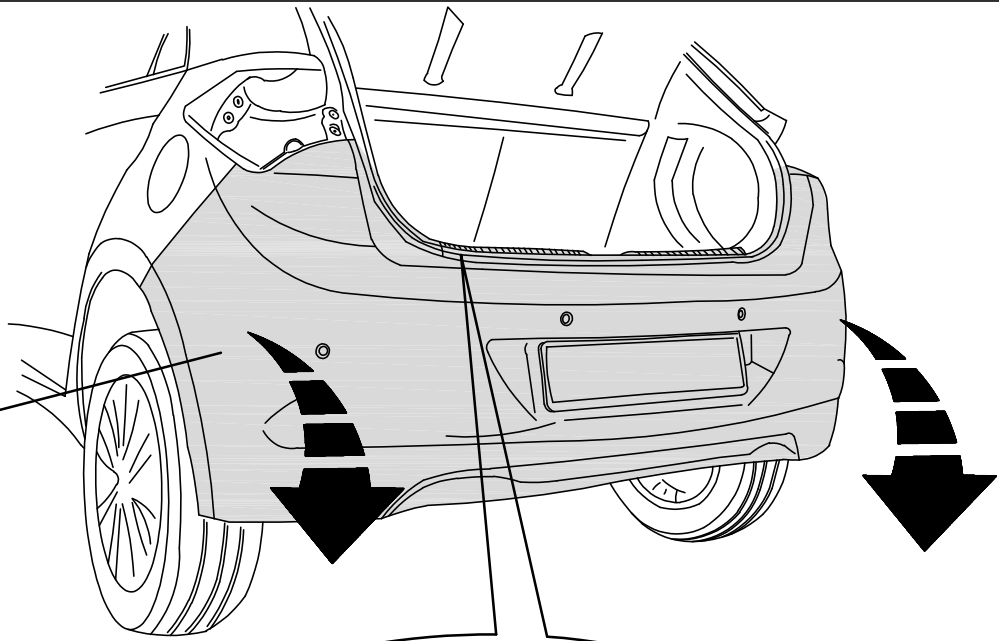

8

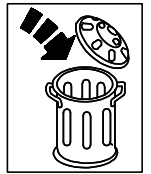
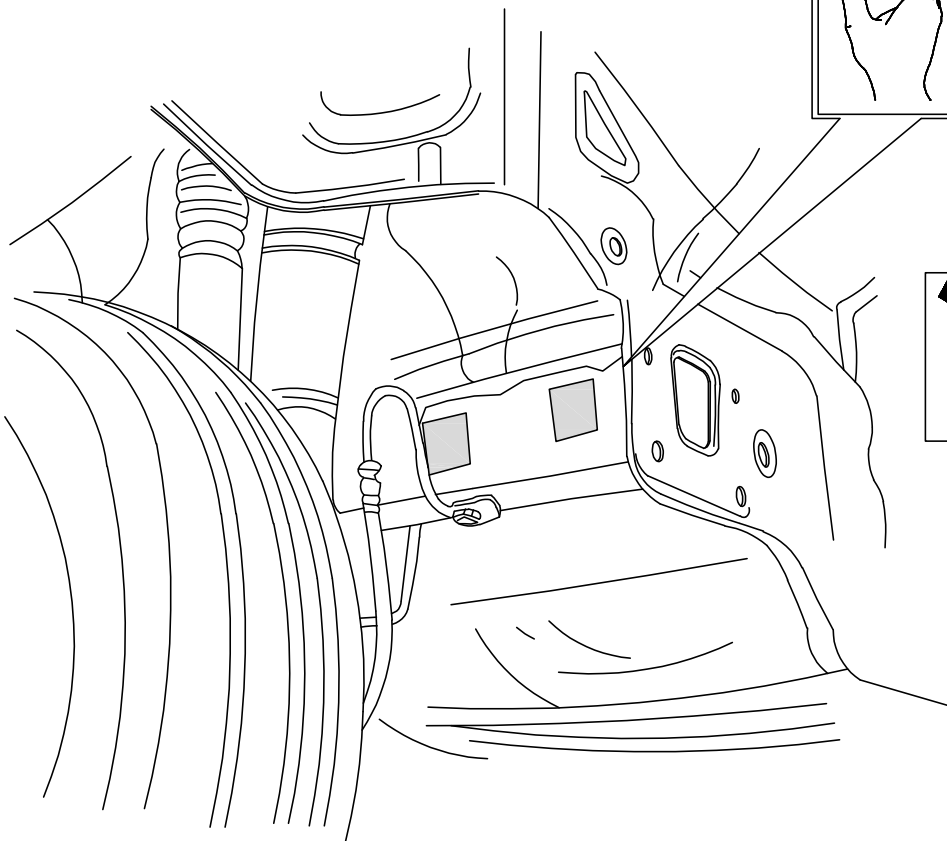
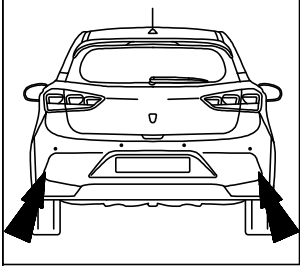

9

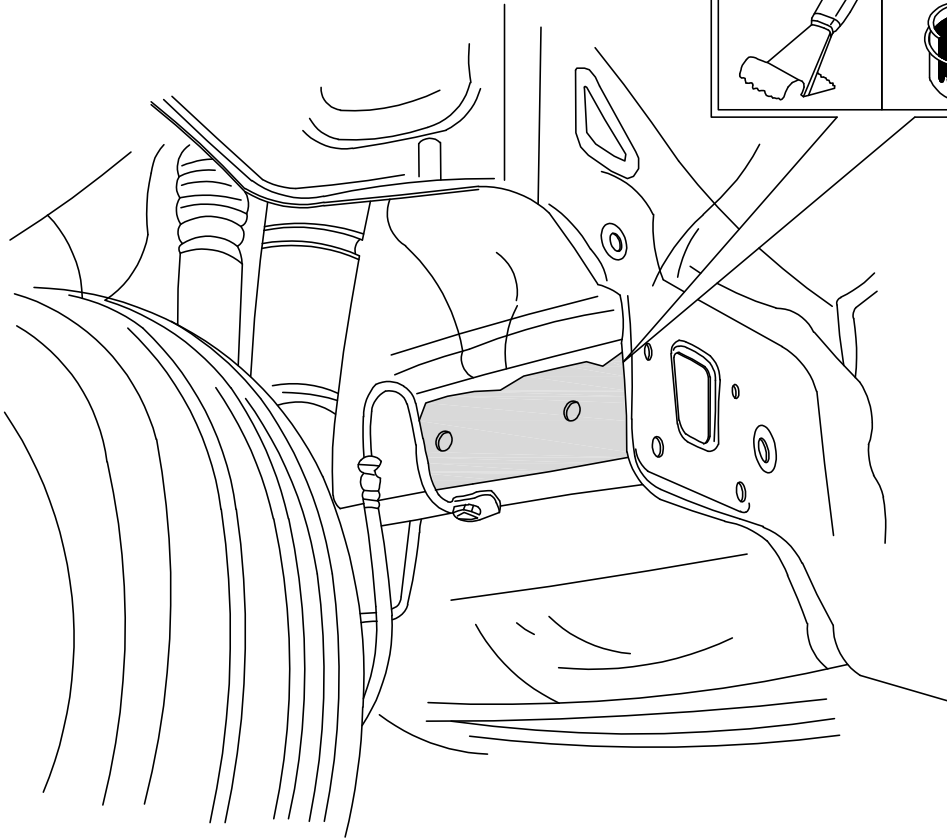
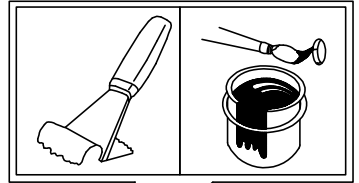
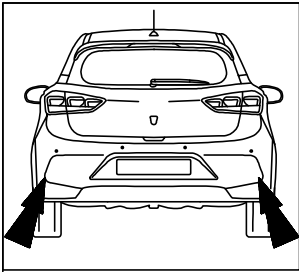

10

Hyundai i20 & i20 FL 2018

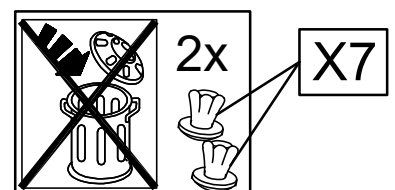
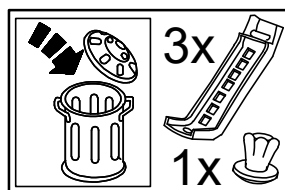
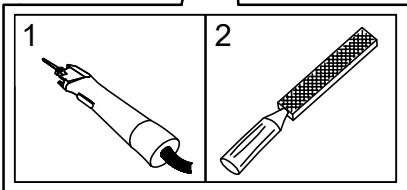
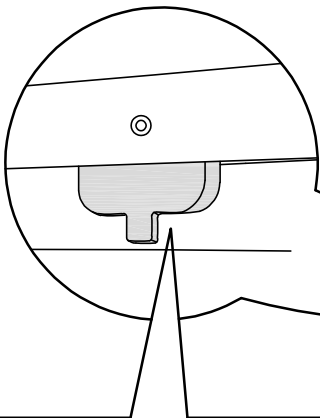
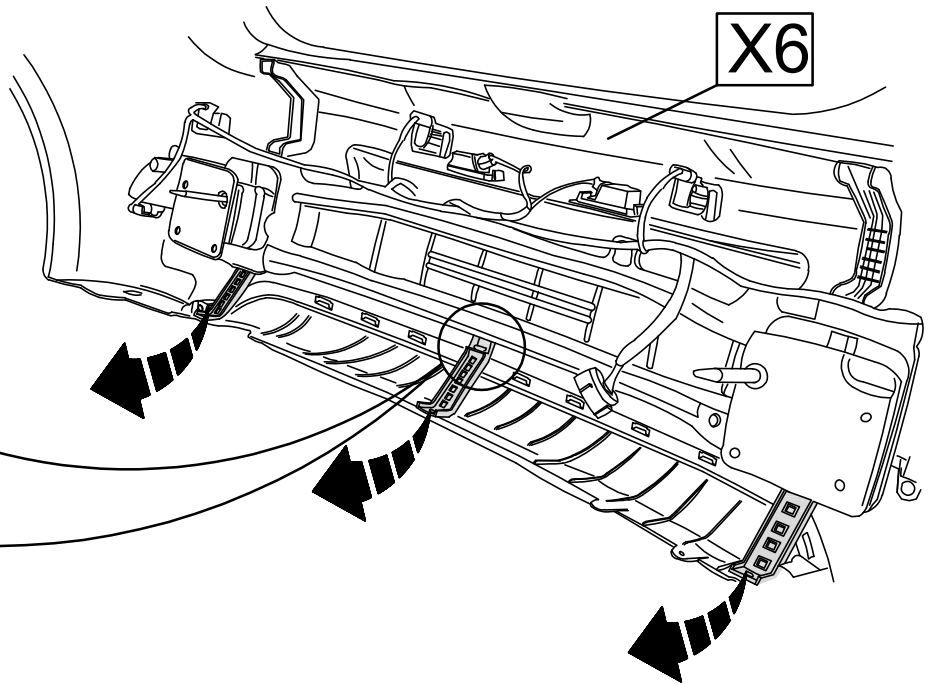

11

Hyundai i20 Coupé

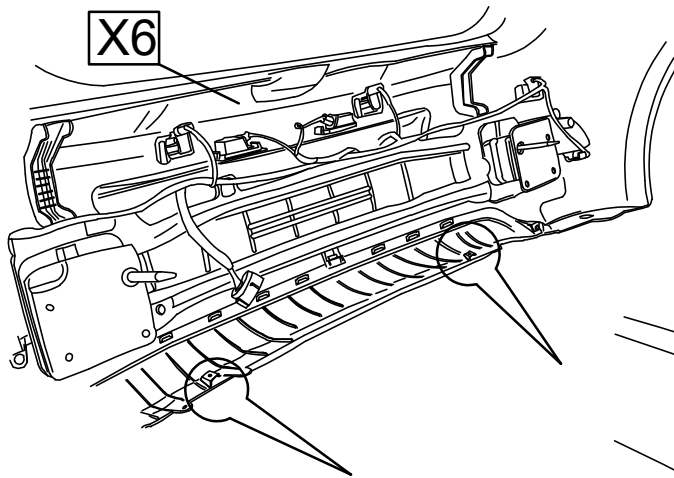
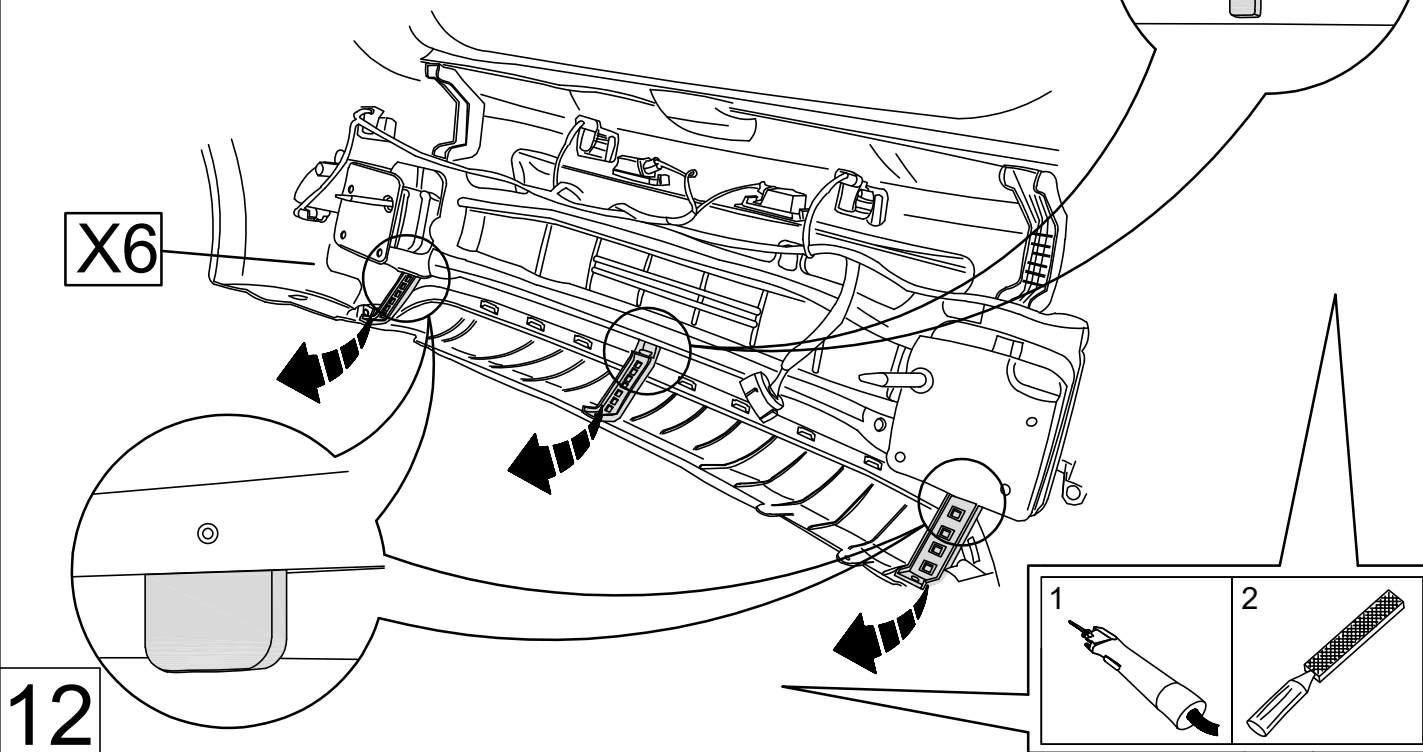
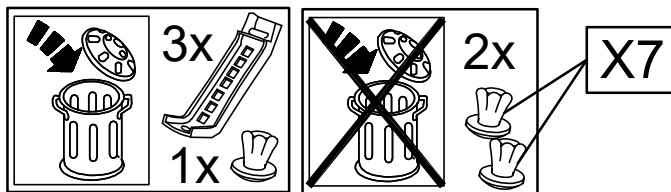

Hyundai i20 FL 2018

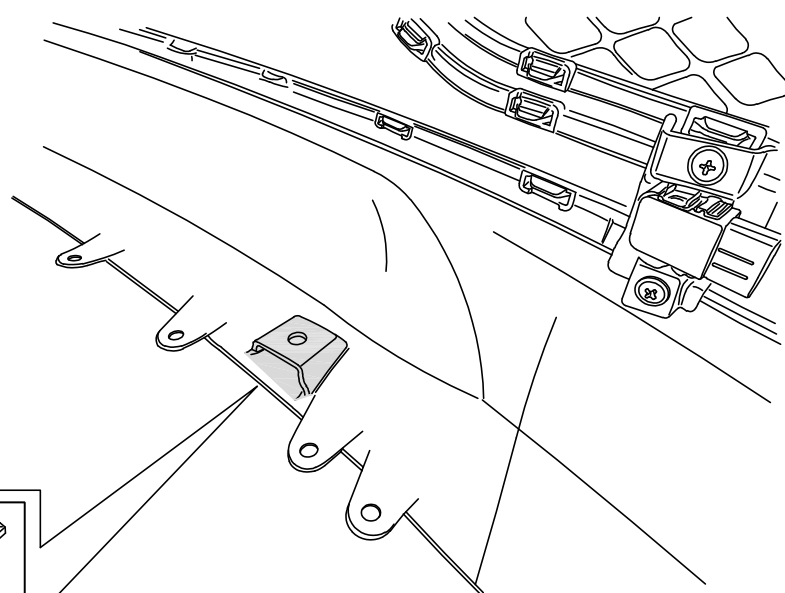

13

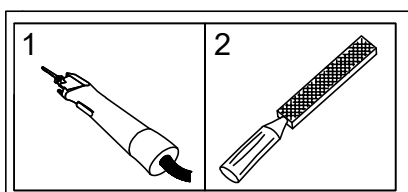

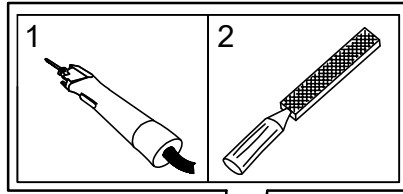
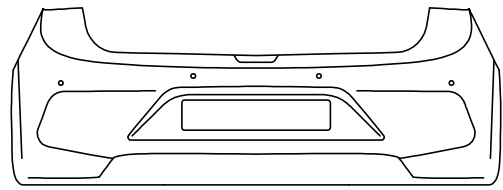

Hyundai i20 & i20 Coupé

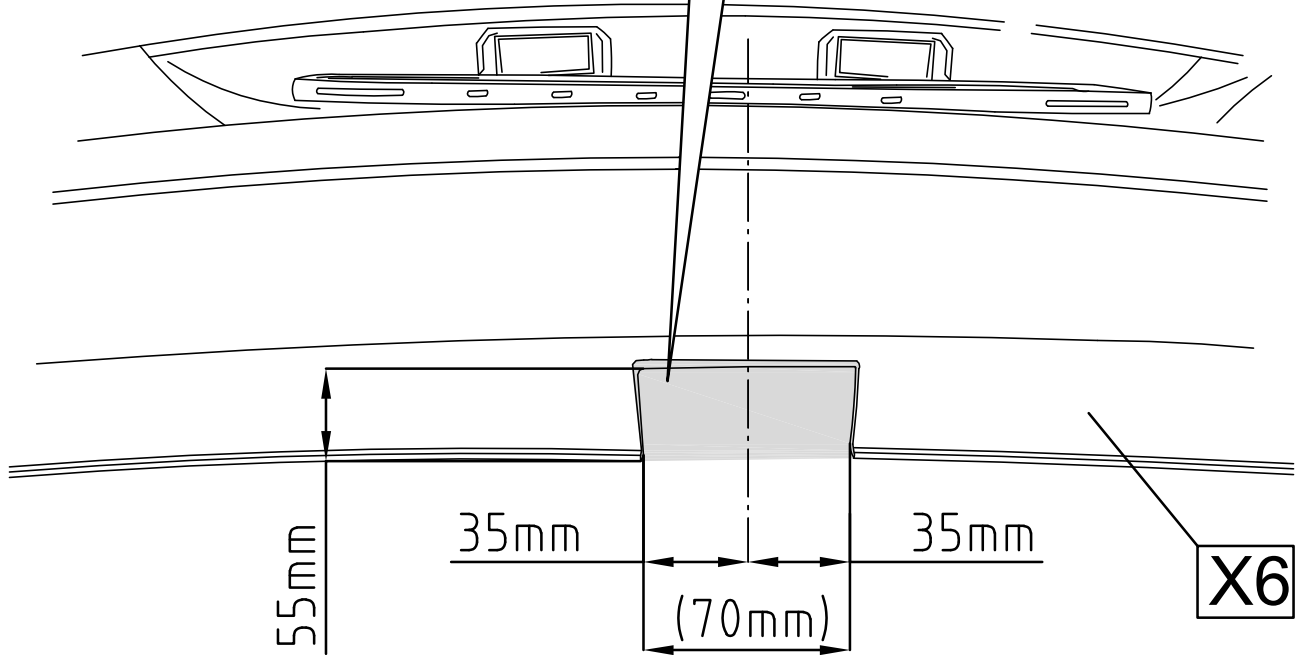

14

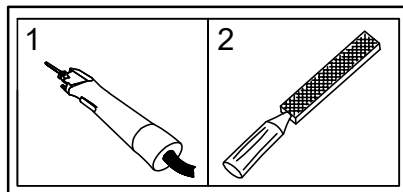
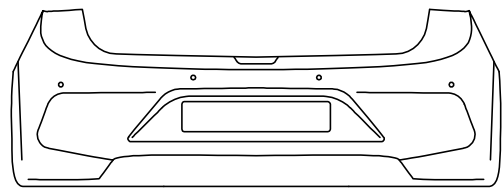

Hyundai i20 FL 2018

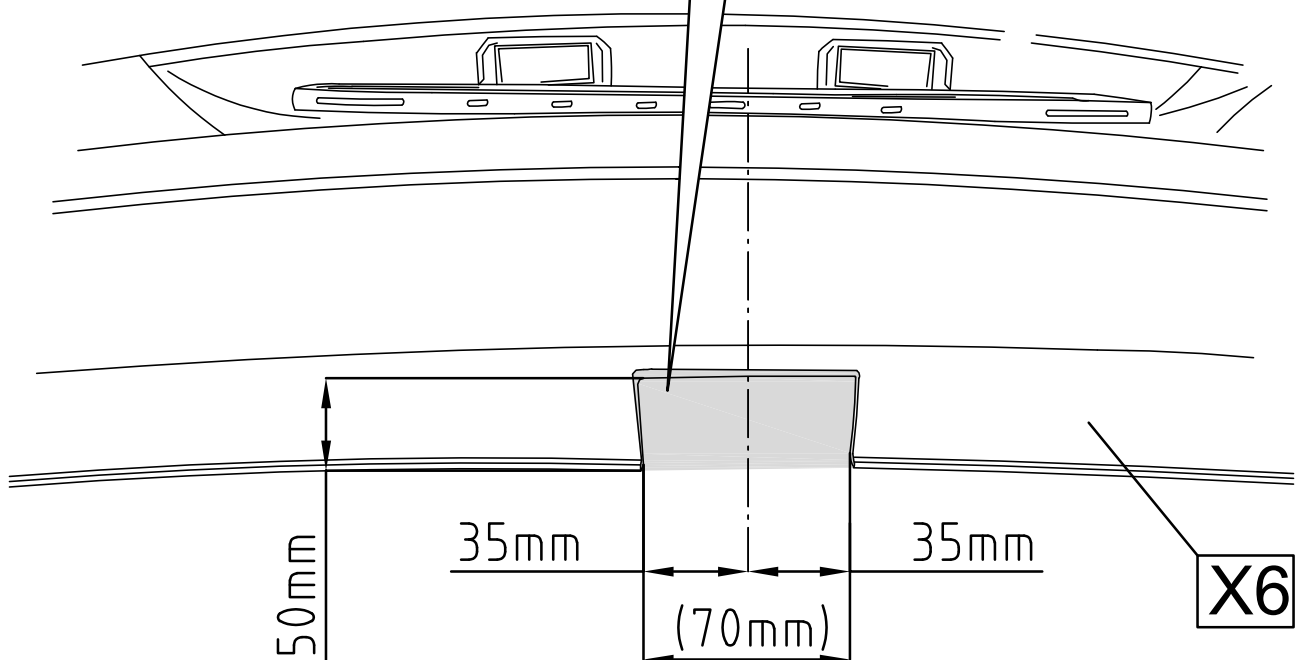

15

Hyundai i20 Active

PDC

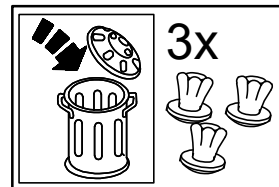
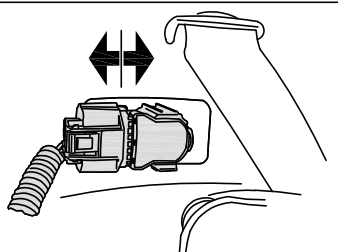
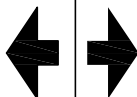

16-20

X6

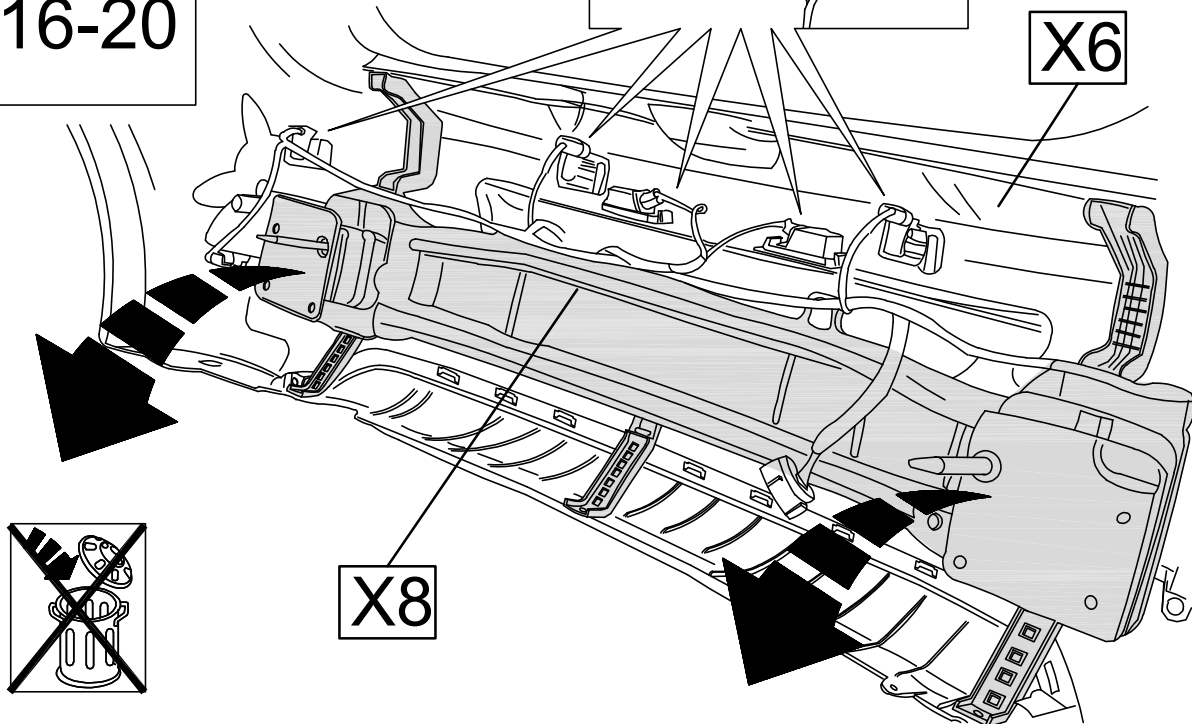

16

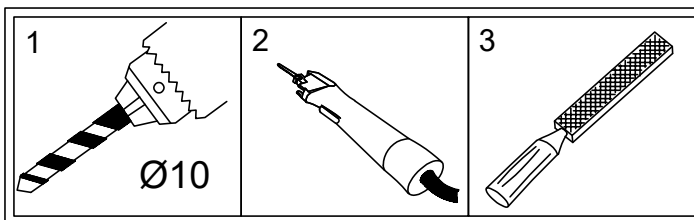

X8

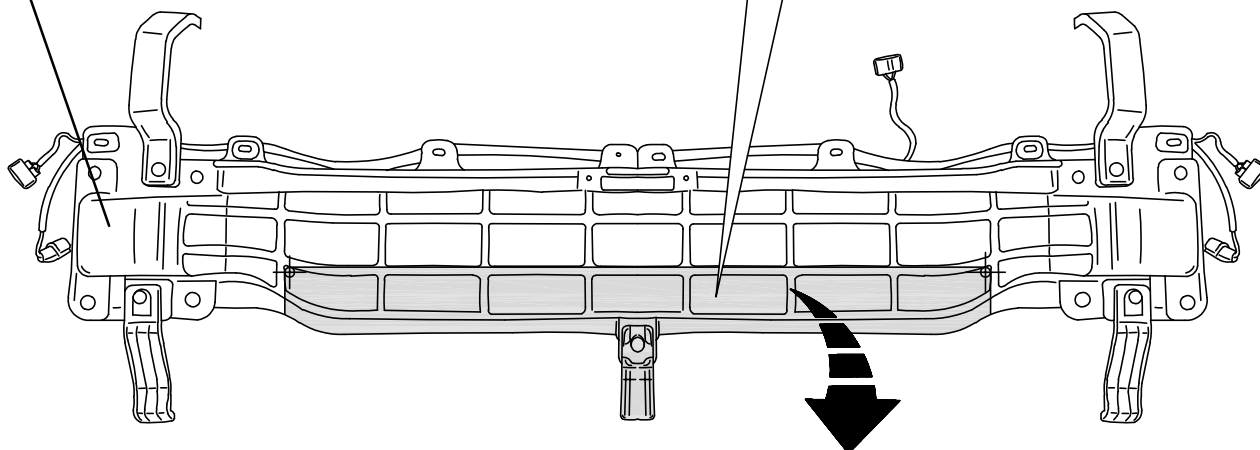

17

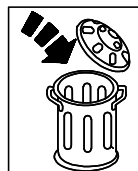

X8

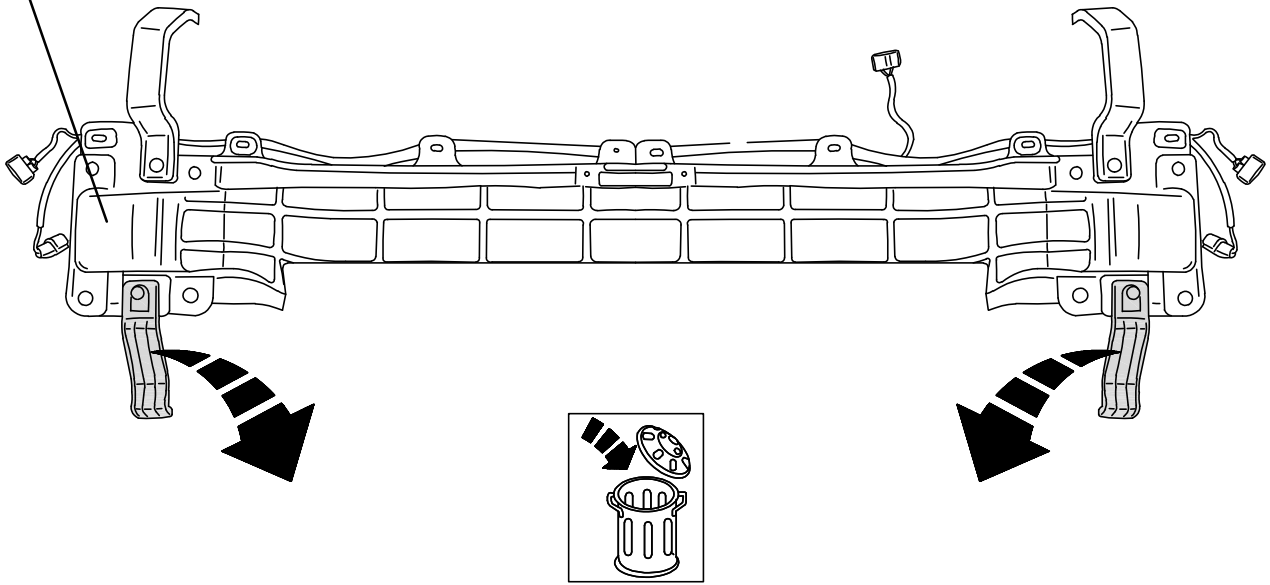

18

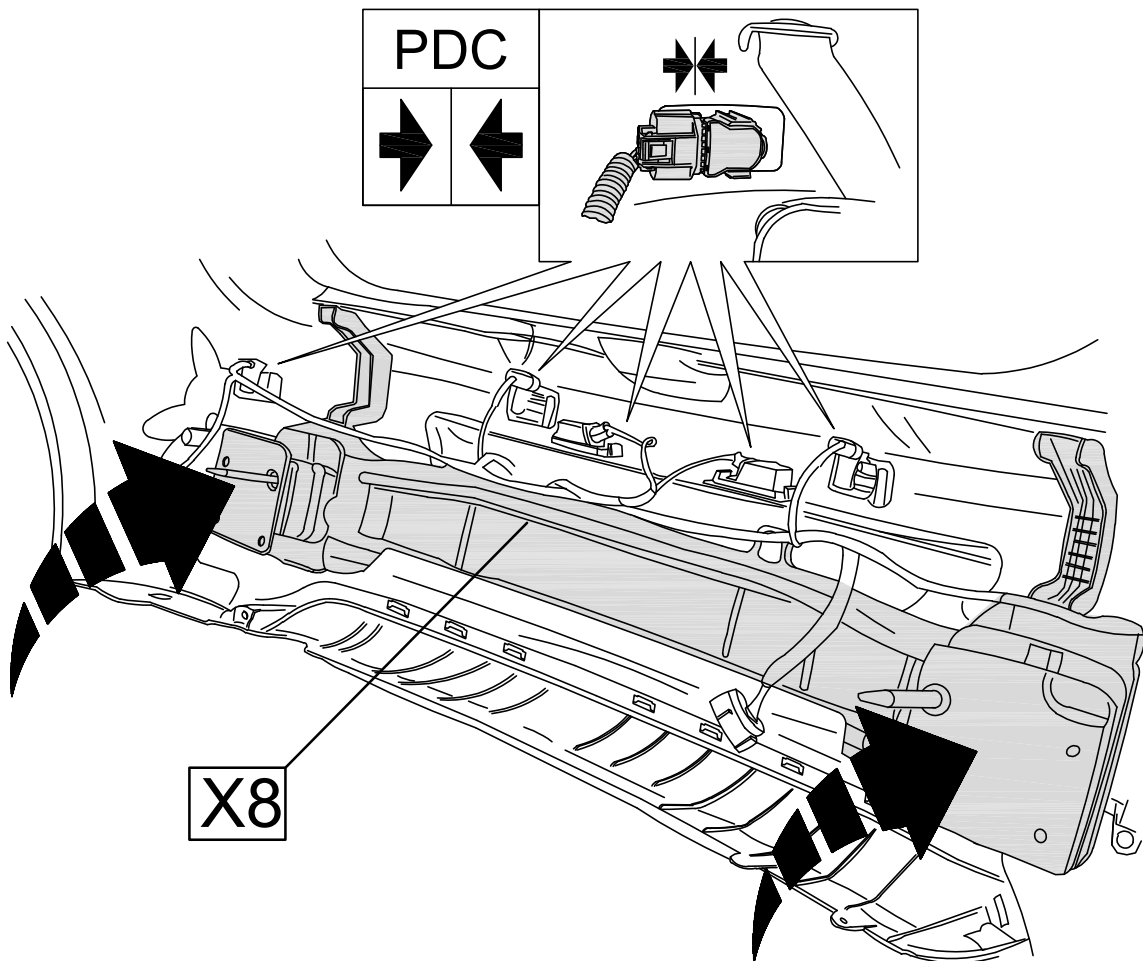

19

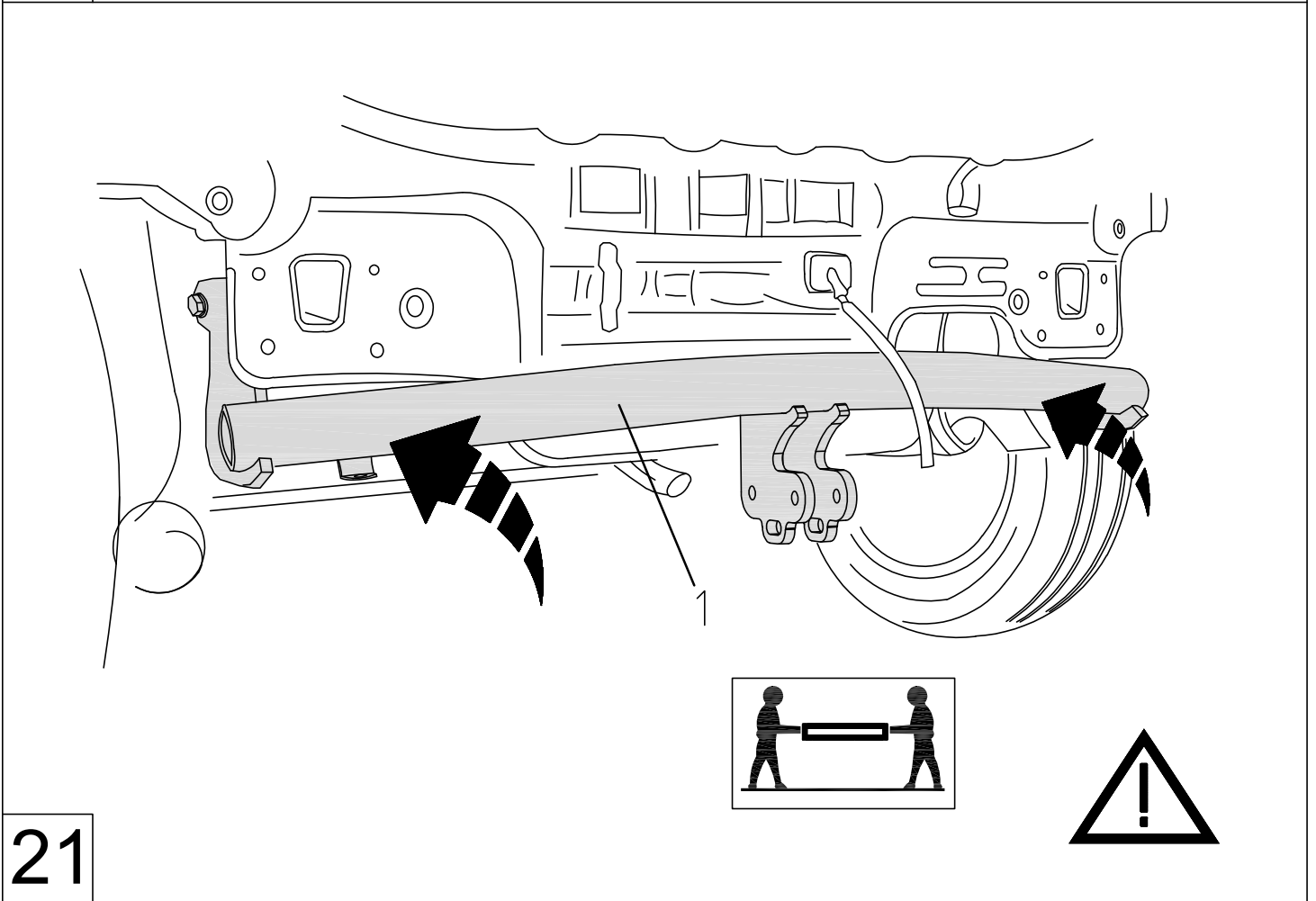
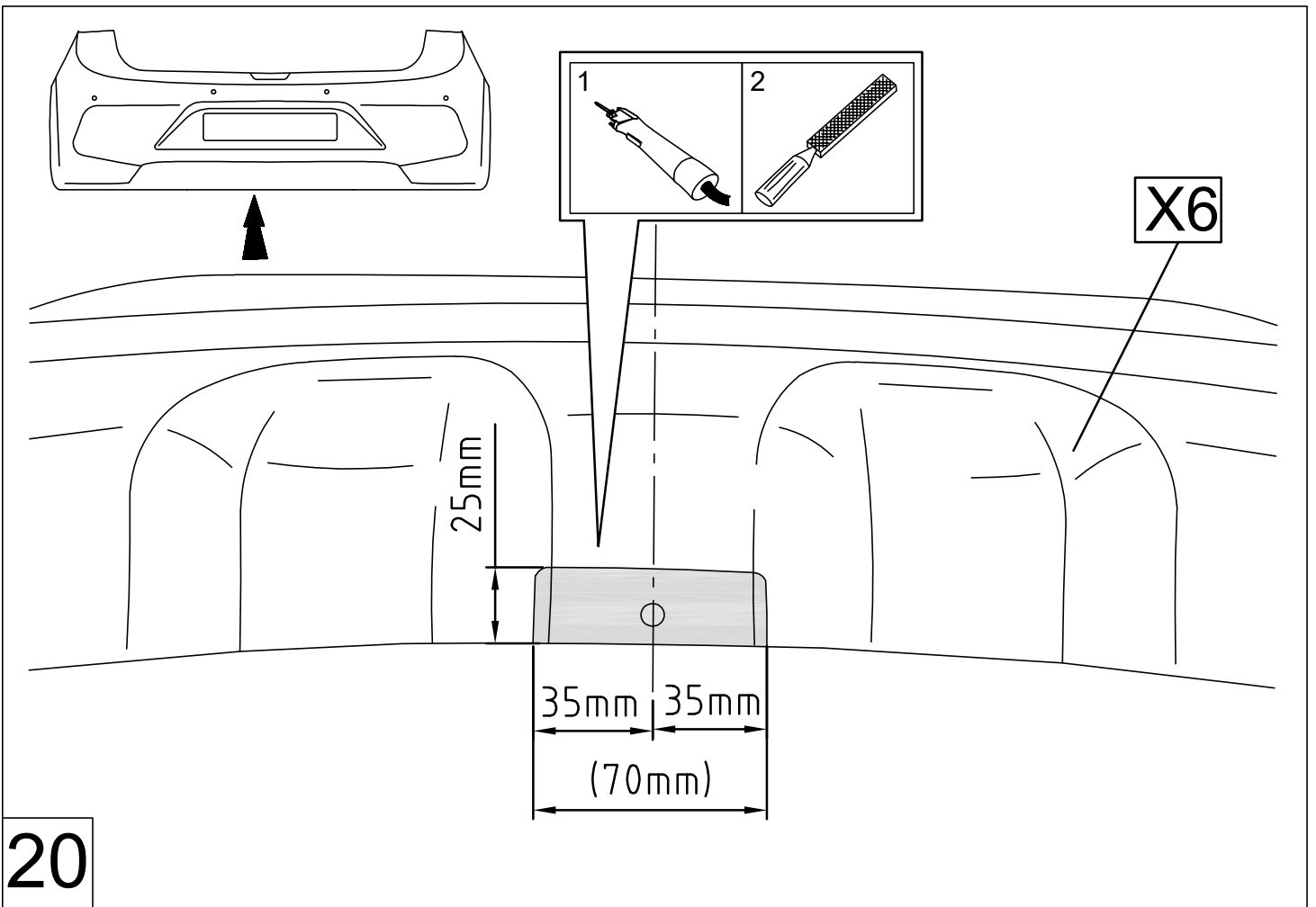

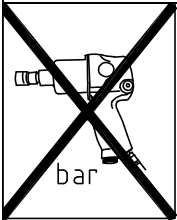
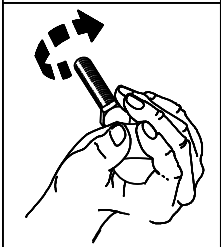
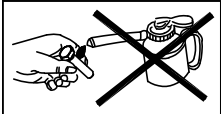
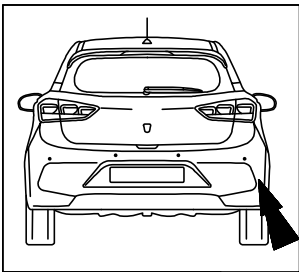

22

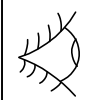

1

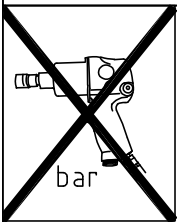
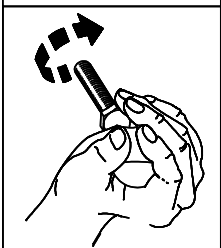
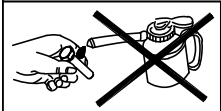
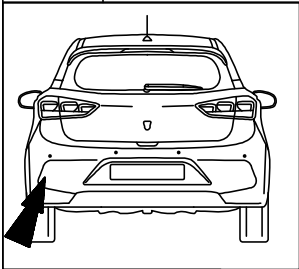
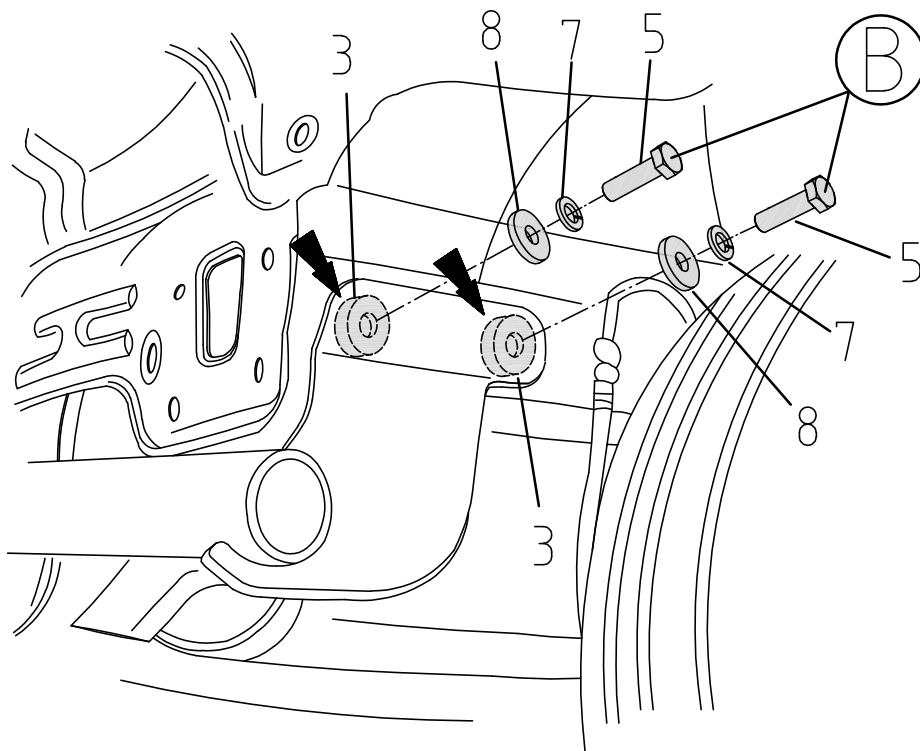



23

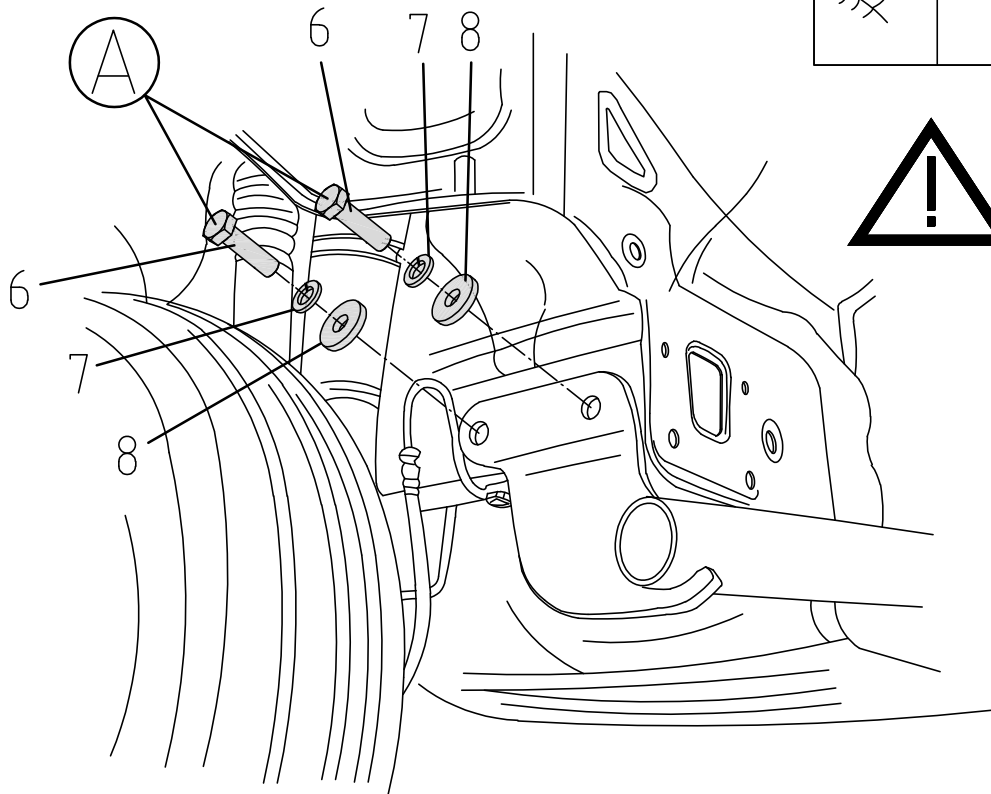

1

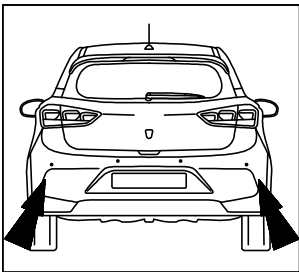



	M12x1.25	8.8	68Nm
---	-----------------	------------	-------------

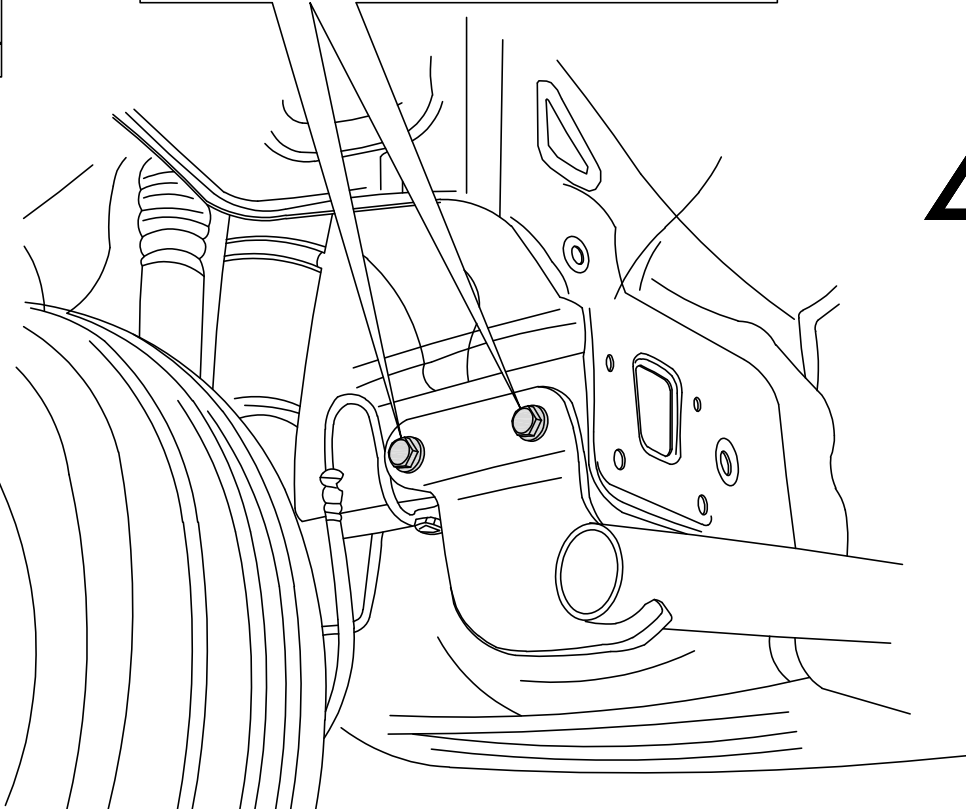
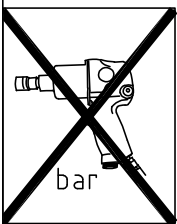

24

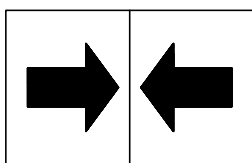
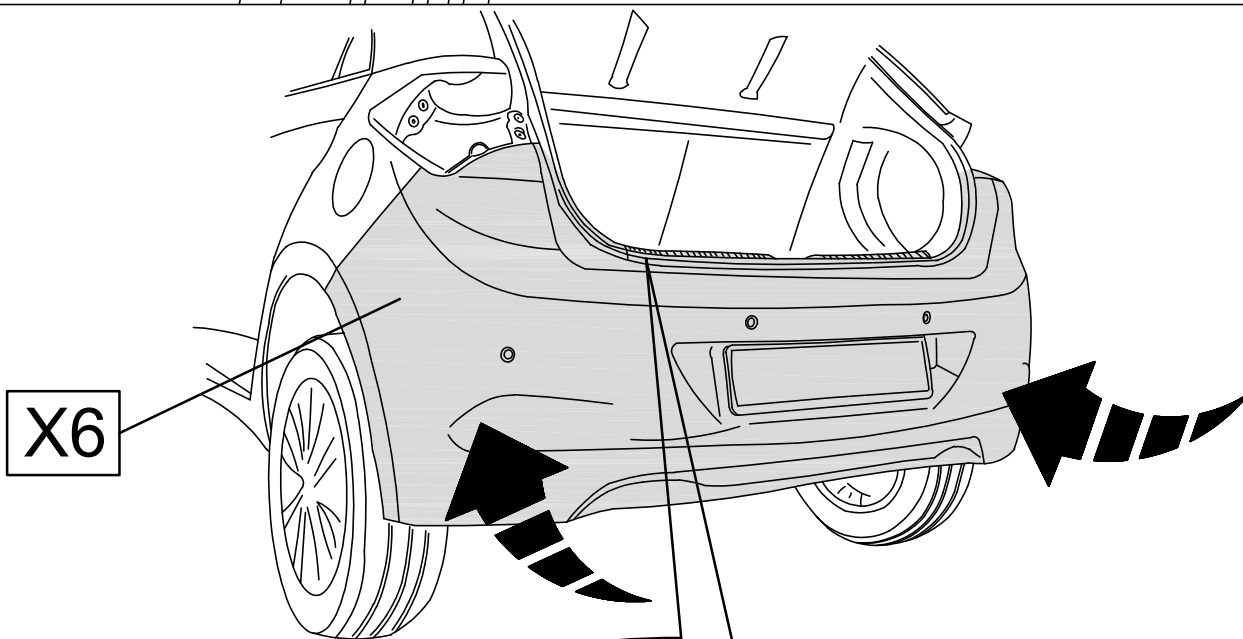

25

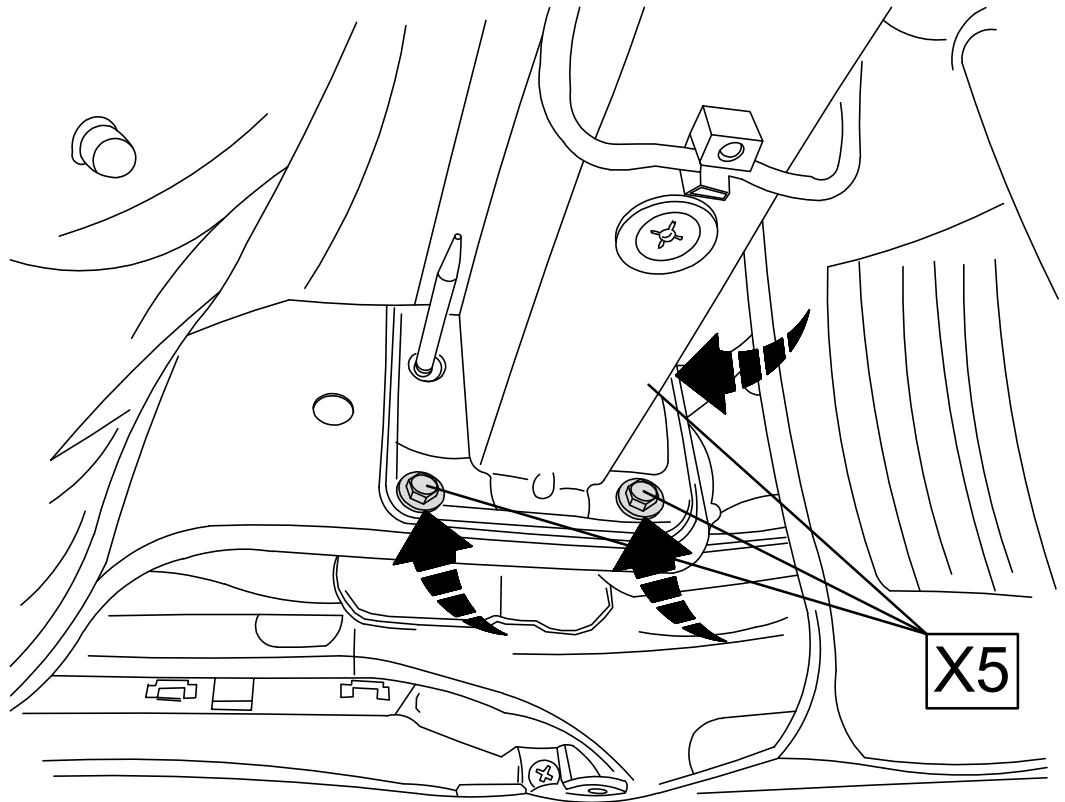
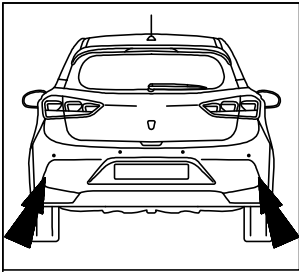

26

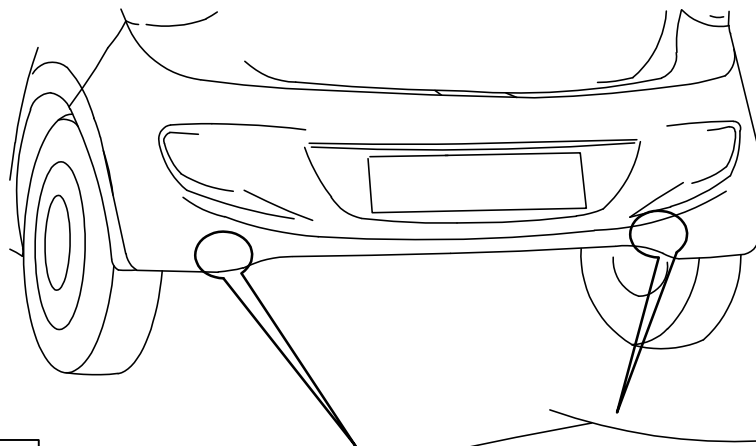
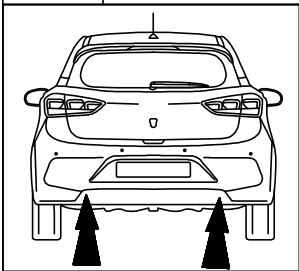

Hyundai
i20

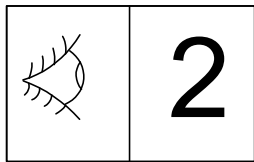

2

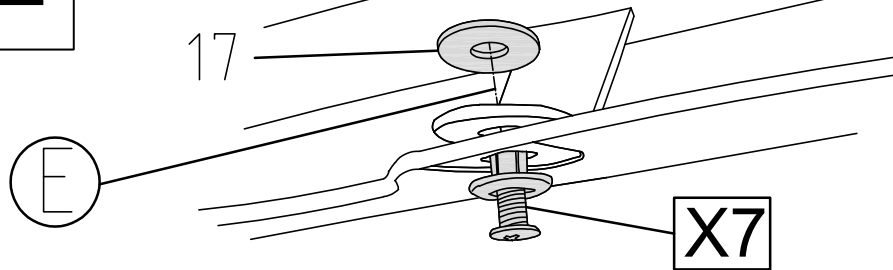

27

X7

Hyundai i20 FL 2018

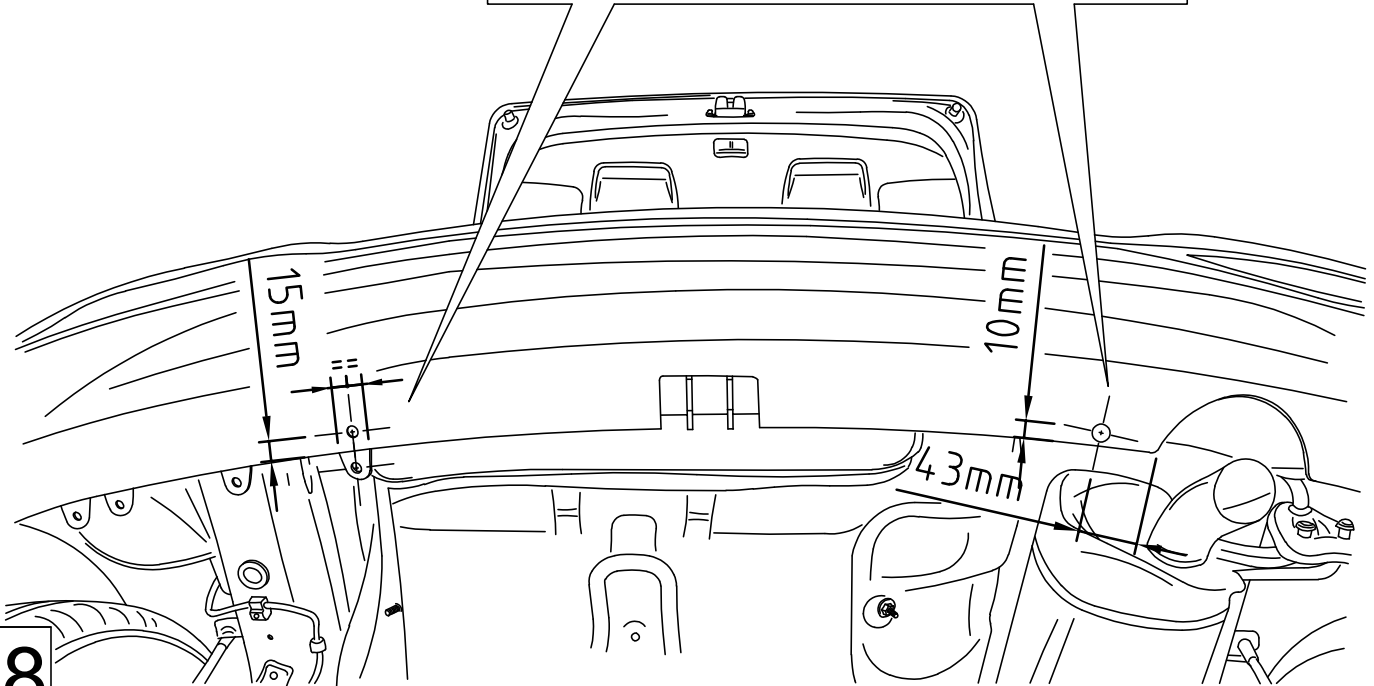
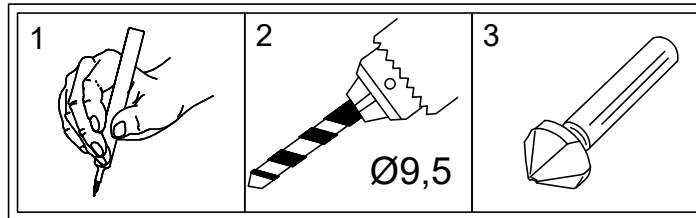

28

Hyundai i20 Coupé & i20 FL 2018

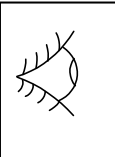
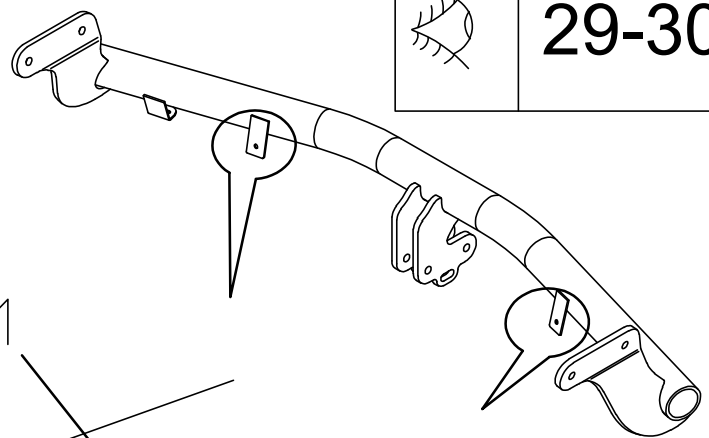

29-30

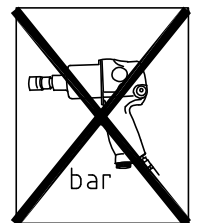
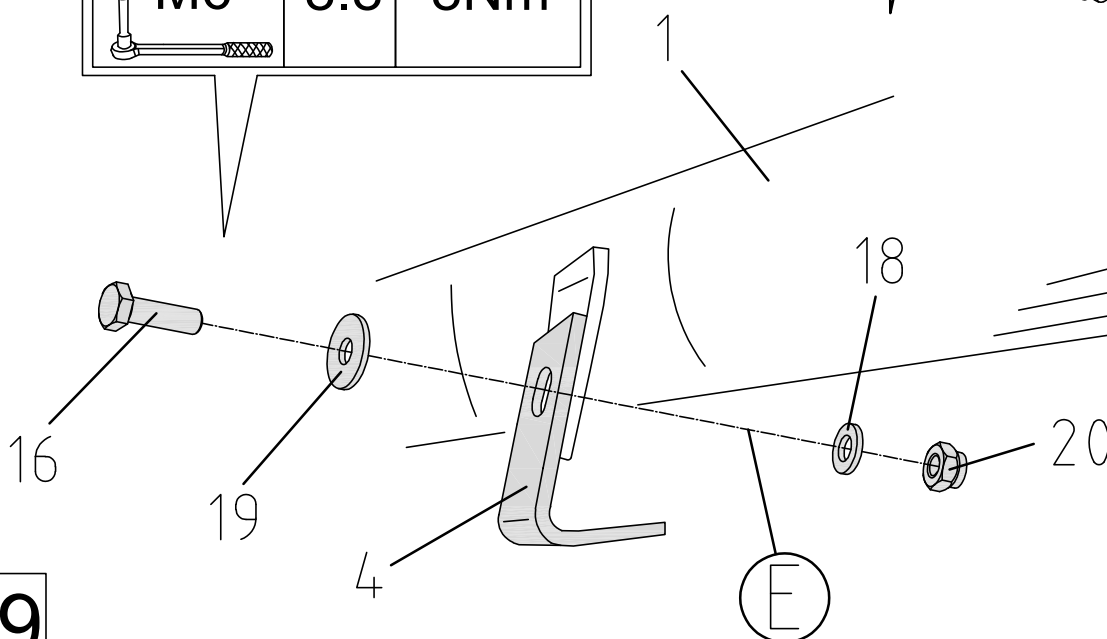
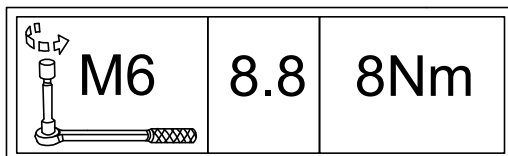

29

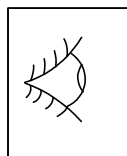

2

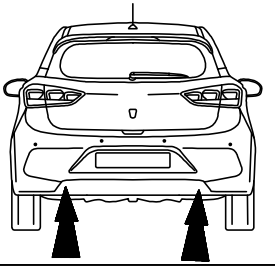

2

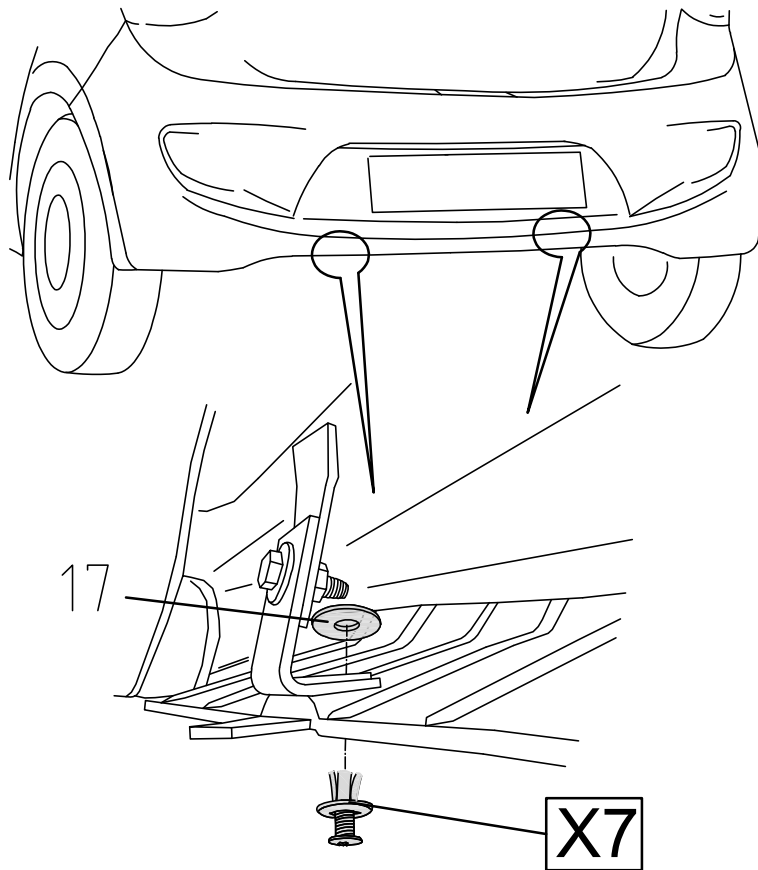

30

X7

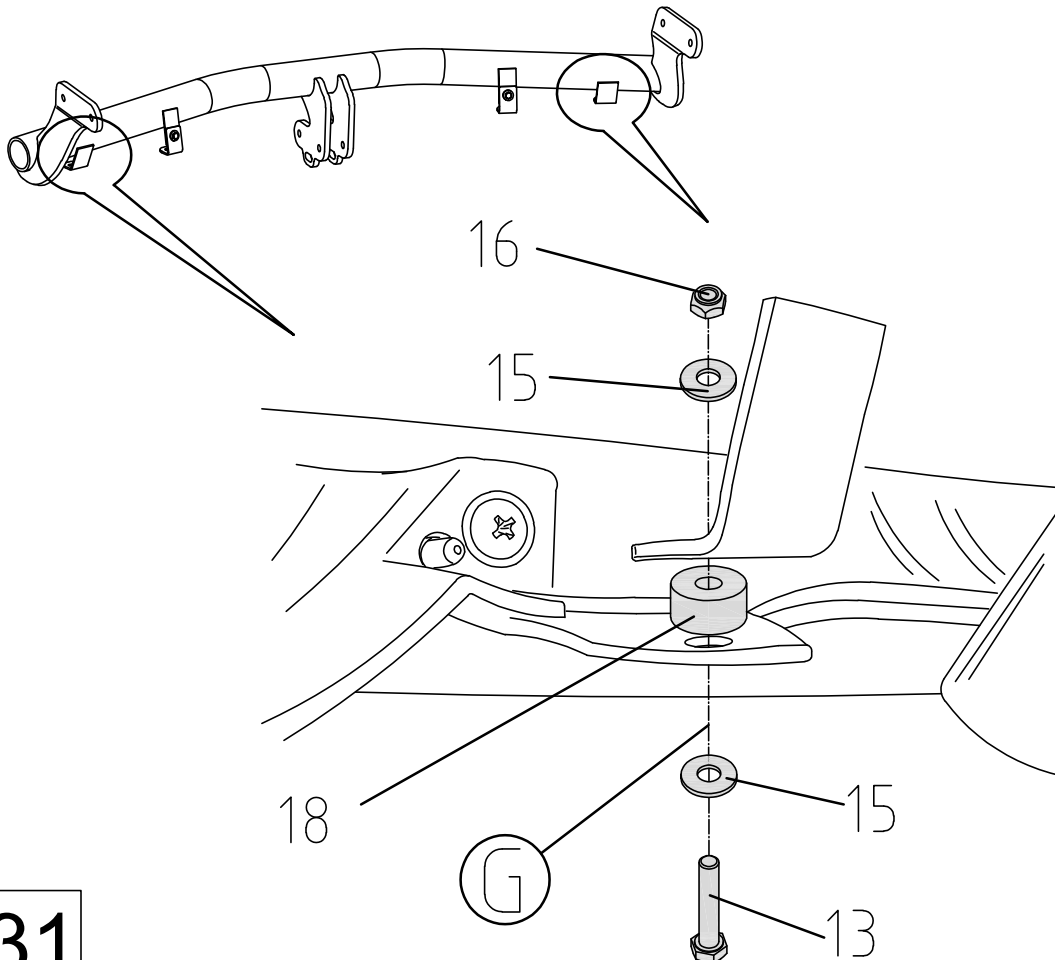

Hyundai
i20 Active



31-32

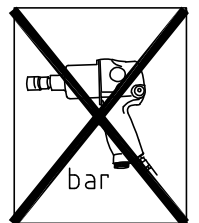

bar

31



3

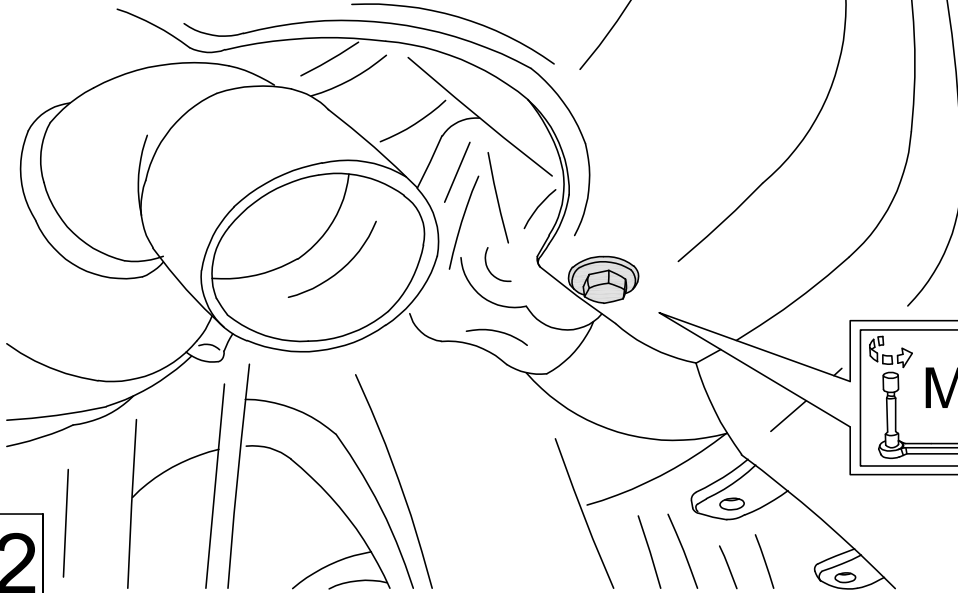
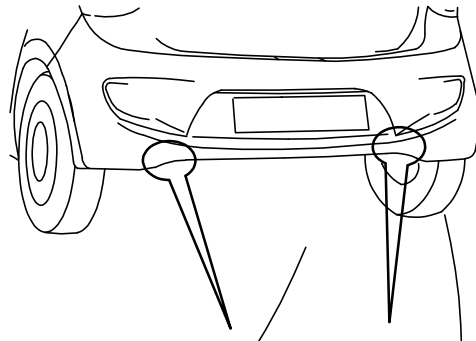
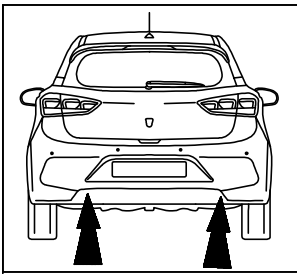

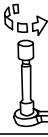
	M6	8.8	8Nm
--	-----------	------------	------------

32

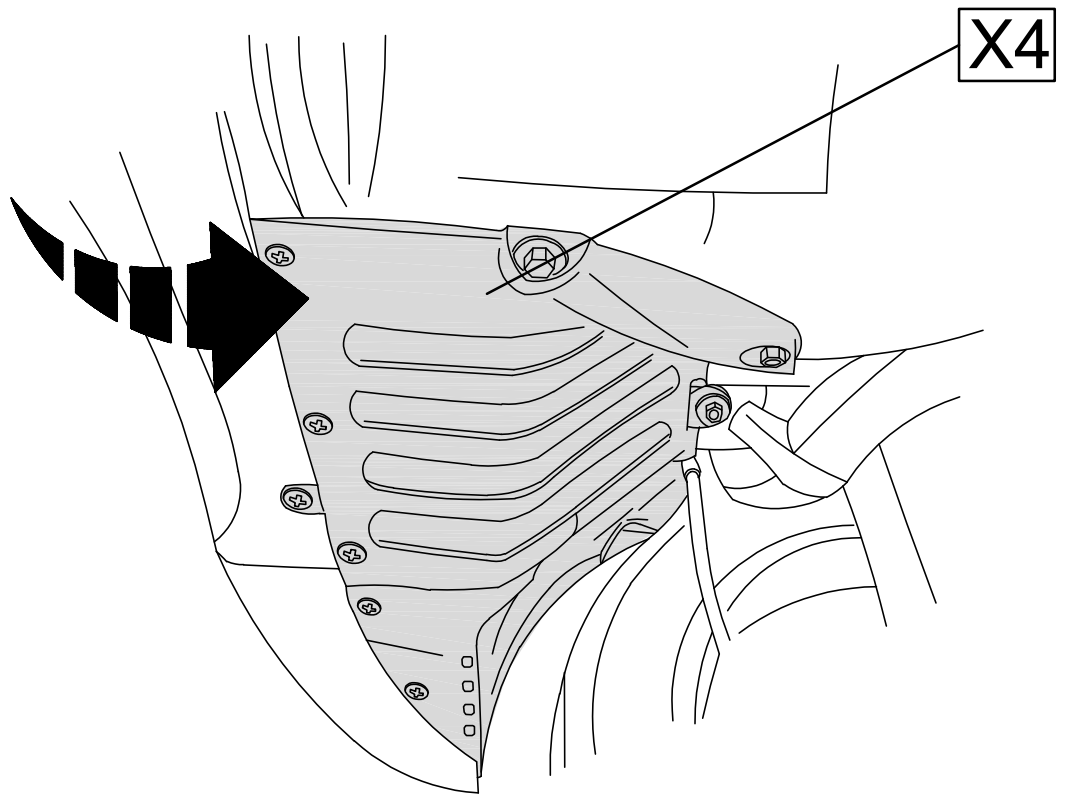
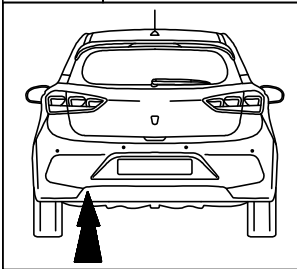

33

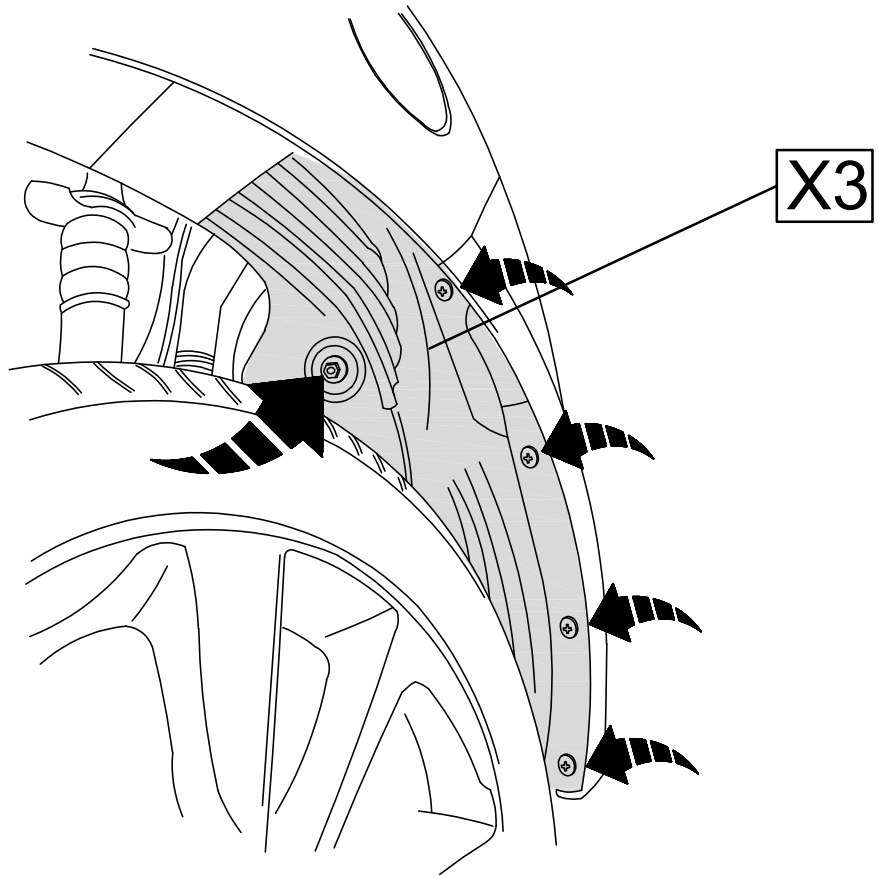
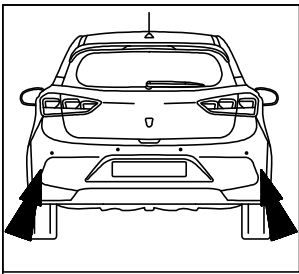

34

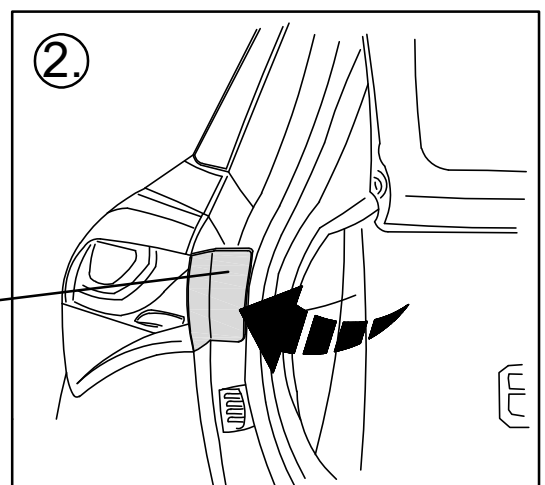
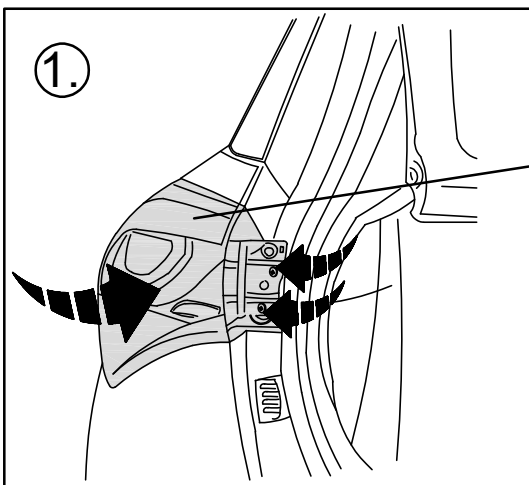
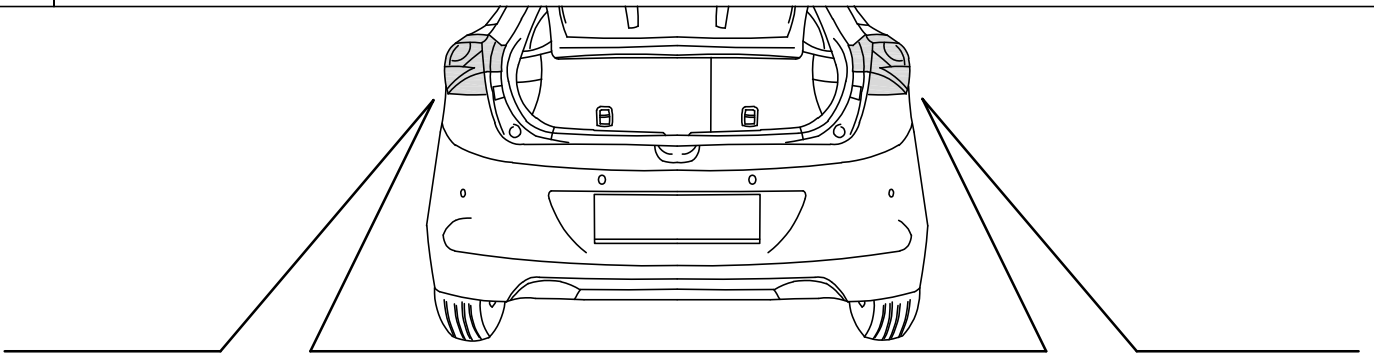

35

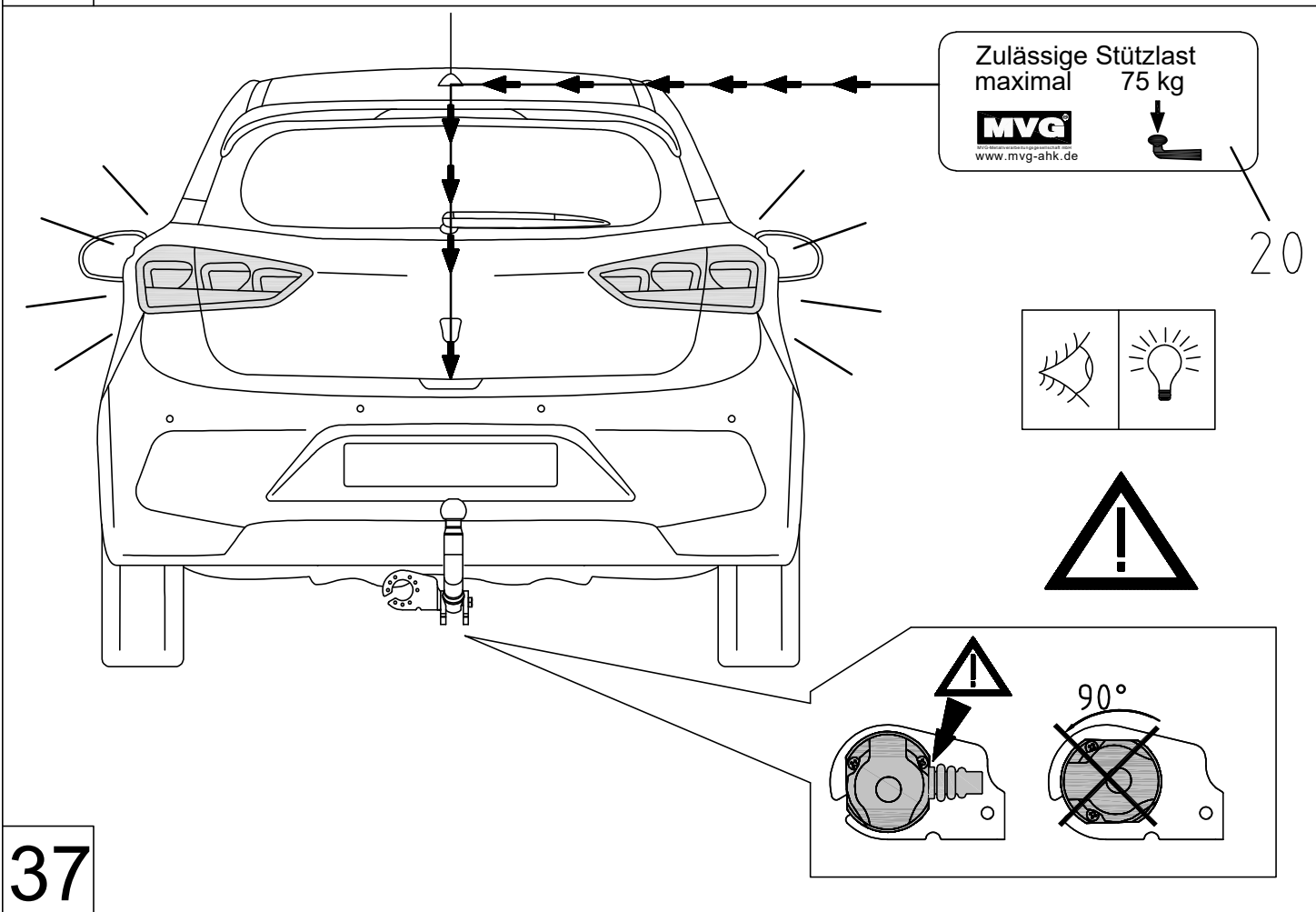
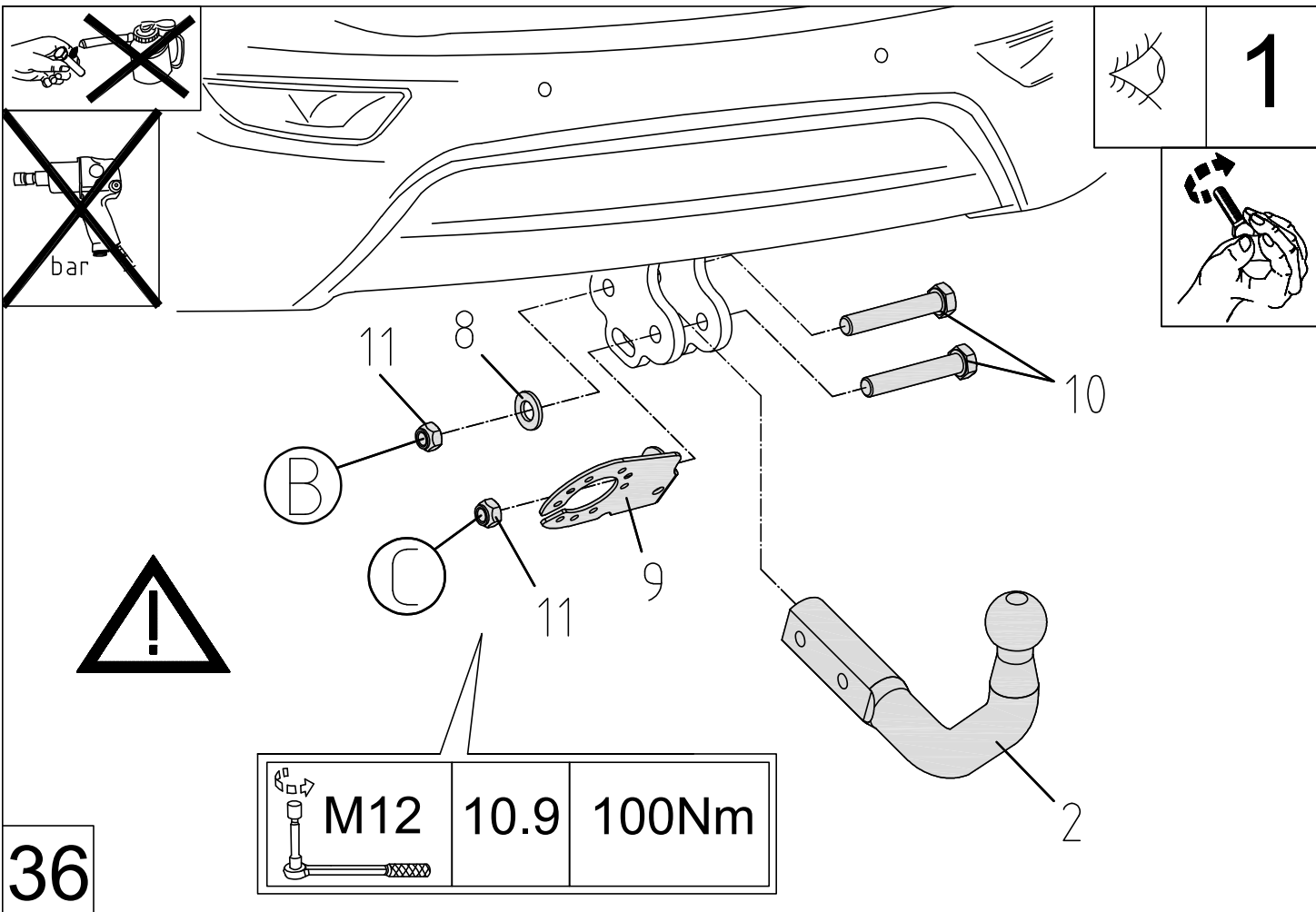

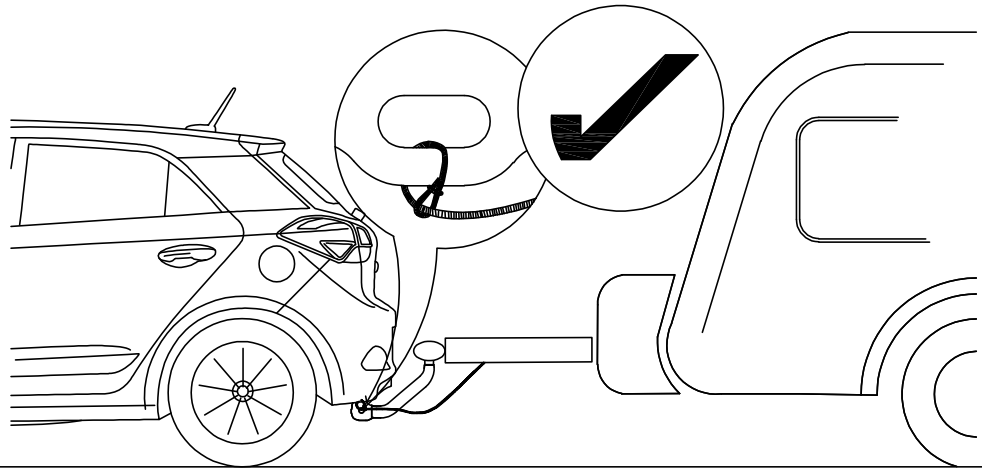
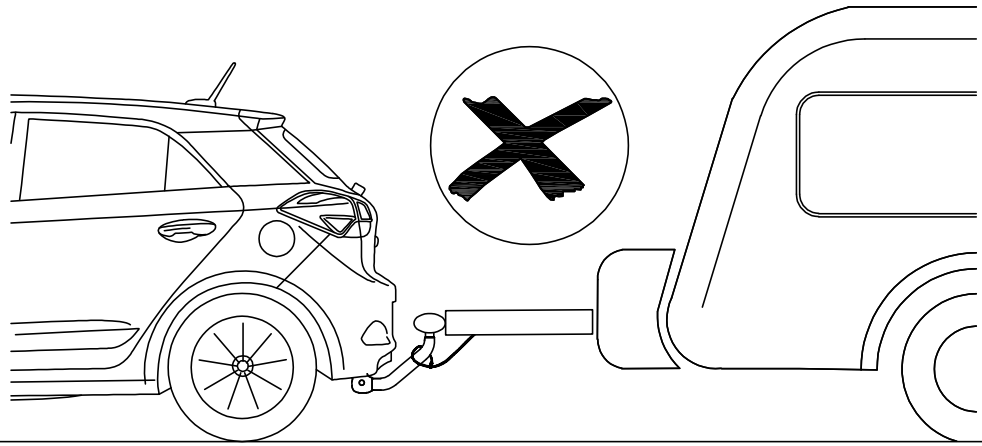

38

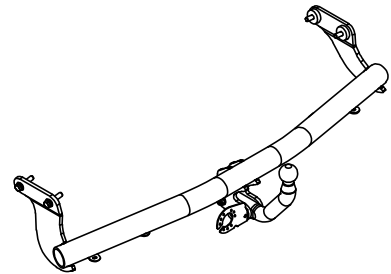
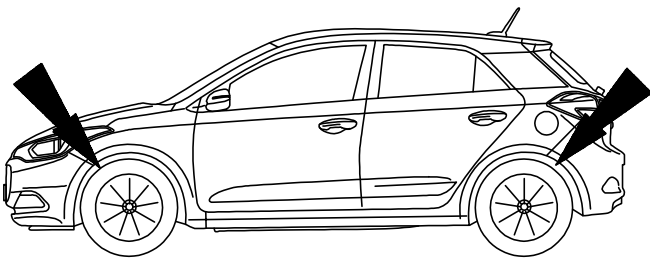

Best. Nr.: 3117 D

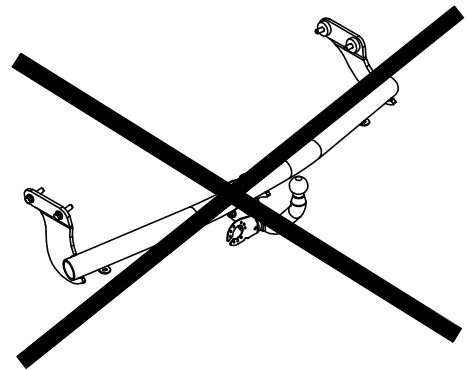
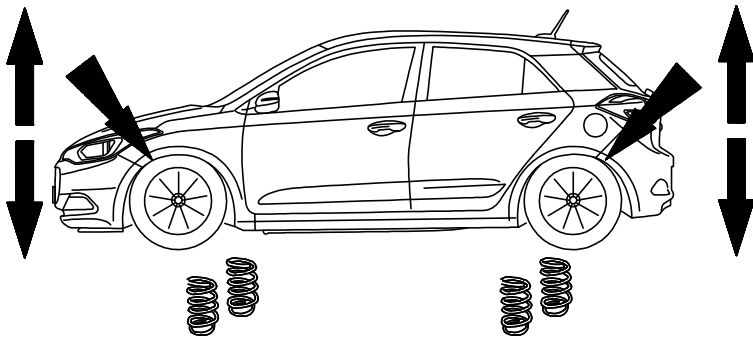

39

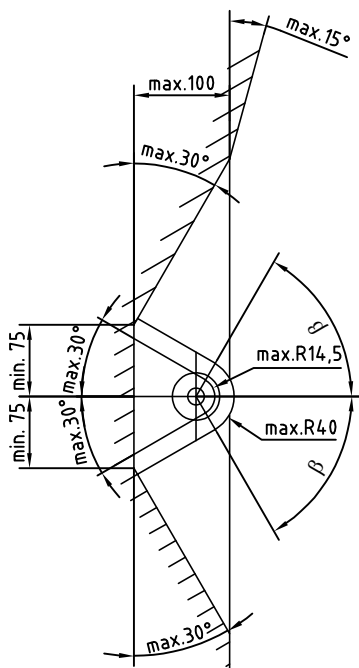
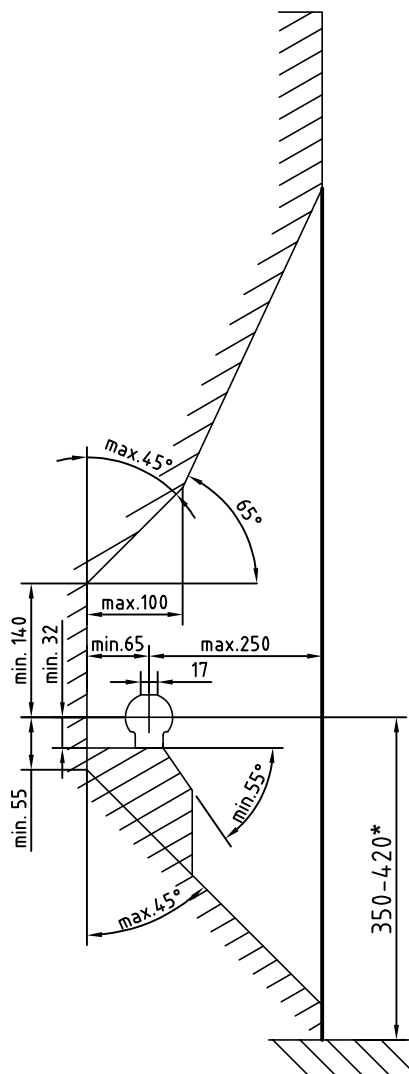

- D** Der Freiraum nach Anhang 7, Abbildung 25a und 25b der Richtlinie ECE-R 55 ist zu gewährleisten.
- CZ** Volný prostor ve smyslu Přílohy 7, obr. 25a a 25b směrnice ECE-R 55 musí být zaručen.
- DK** Det skal sikres, at der er spillerum i overensstemmelse med bilag 7, fig. 25a og 25b i henhold til direktiv ECE-R 55.
- E** Hay que garantizar el espacio libre conforme al anexo 7, fig. 25a y 25b de la directiva ECE-R 55.
- F** La zone de dégagement, selon l'annexe 7, figure 25a et 25b de la directive ECE-R 55, doit être assurée.
- FIN** Välyksen tulee täyttää ohjeen ECE-R 55 liitteen 7 kuvissa 25a ja 25b ilmoitetut vaatimukset.
- GB** Make sure to provide clearance according to appendix 7, figures 25a and 25b of the ECE-R 55 regulations.
- GR** Πρέπει να εξασφαλίζεται ο ελεύθερος χώρος σύμφωνα με το παράρτημα 7, σχήμα 25a και 25b της κοινοτικής οδηγίας ECE-R 55.
- H** Biztosítani kell az ECE-R 55 irányelv szerinti, 7. számú függelék, 25a. és 25b ábrákban jelölt szabad teret.
- I** Deve essere garantito lo spazio libero secondo l'allegato 7, figure 25a e 25b della normativa europea ECE-R 55.
- N** Det må sørges for fritt rom i samsvar med tillegg 7, figur 25a og 25b i direktiv ECE-R 55.
- NL** De vrije ruimte volgens supplement 7, afbeelding 25a en 25b van richtlijn ECE-R 55 moet gewaarborgd zijn.
- PL** Należy zapewnić wolną przestrzeń zgodnie z załącznikiem 7, rys. 25a i 25b, dyrektywy ECE-R 55.
- RUS** Оставлять свободное пространство согласно Приложению 7, рис. 25a и 25b Директивы ECE-R 55.
- S** Spelrummet enligt bilaga 7, bild 25a och 25b i riktlinje ECE-R 55, måste garanteras.

- D** * bei zulässigem Gesamtgewicht des Fahrzeuges
- CZ** * při celkové přípustné hmotnosti vozidla
- DK** * ved tilladt totalvægt for køretøjet
- E** * con peso total autorizado del vehículo
- F** * pour poids total en charge autorisé du véhicule
- FIN** * Ajoneuvon suurimmalla sallitulla kokonaispainolla
- GB** * at gross vehicle weight rating
- GR** * για το επιτρεπτό μικτό βάρος του οχήματος
- H** * A jármű megengedett összsúlya esetén
- I** * per il peso complessivo ammesso del veicolo
- N** * ved kjøretøyets tillatte totalvekt
- NL** * bij toegestaan totaal gewicht van het voertuig
- PL** * przy dopuszczalnym ciężarze całkowitym pojazdu
- RUS** * при допустимом общем весе автомобиля
- S** * vid fordonets tillåtna totalvikt

- D** Die Anhängervorrichtung ist ein Sicherheitsteil und darf nur von Fachunternehmen montiert werden. Bei falscher Montage besteht schwere Unfallgefahr! Der deutsche Text dieser Anleitung ist bindend.
- CZ** Tažné zařízení je bezpečnostní součást, kterou smí montovat pouze odborné podniky. Při chybné montáži hrozí vážné nebezpečí nehody! Německý text tohoto návodu je závazný.
- DK** Anhængertrækket er en sikkerhedsdel og må kun monteres af autoriserede firmaer. Ved forkert montering er der fare for alvorlige uheld! Den tyske tekst i denne vejledning er bindende.
- E** La bola de enganche es un elemento de seguridad y sólo se debe permitir su montaje a personal cualificado. ¡En caso de montaje erróneo existe peligro de accidentes graves! Es vinculante el texto alemán de estas instrucciones.
- F** Le dispositif d'attelage est un équipement de sécurité et doit être mis en place exclusivement par un atelier spécialisé. Un montage incorrect représente un risque élevé d'accident! Le texte allemand de cette notice fait foi.
- FIN** Vetolaite on turvallisuuteen vaikuttava osa, jonka saa asentaa vain alan erikoisliike. Virheellinen asennus voi aiheuttaa vakavan onnettomuuden! Tämän ohjeen saksankielinen teksti on sitova.
- GB** A trailer hitch is a safety-critical part and may be fitted only by qualified companies. Improper assembly may result in a serious accident hazard! The German text of this instruction is binding.
- GR** Ο κοτσαδόρος είναι ένα εξάρτημα ασφαλείας και η τοποθέτηση του επιτρέπεται να γίνεται μόνο από εξειδικευμένο συνεργείο. Σε περίπτωση λάθους τοποθέτησης υπάρχει κίνδυνος σοβαρών ατυχημάτων! Το γερμανικό κείμενο αυτών των οδηγιών είναι δεσμευτικό.
- H** A vonószerkezet egy biztonságos felszerelés, amelyet csak szaküzem szerelhet fel. Helytelen szerelés súlyos balesethez vezethet! A német szerelési utasítás betartása kötelező.
- I** Il gancio di traino è un componente di sicurezza e deve essere montato esclusivamente da personale specializzato. In caso di montaggio errato sussiste il pericolo di incidenti gravi! È vincolante il testo tedesco di queste istruzioni.
- N** Tilhengerfestet er en sikkerhetskompoment og skal monteres av fagbedrift. Det er stor fare for at det kan oppstå ulykker ved feil montering! Den tyske teksten i denne veiledningen er bindende.
- NL** De aanhanger is veiligheidsonderdeel en mag alleen door vakkundig personeel worden gemonteerd. Bij verkeerde montage bestaat ernstig gevaar voor ongevallen! De Duitse tekst van deze handleiding is bindend.
- PL** Hak holowniczy stanowi element bezpieczeństwa i może zostać zamontowany wyłącznie przez firmę specjalistyczną. W przypadku nieprawidłowego montażu istnieje poważne ryzyko wypadku! Tekst niniejszej instrukcji w języku niemieckim jest wiążący.
- RUS** Сцепное устройство - это узел, несущий предохранительные функции, и к его монтажу допускаются только специалисты. При неправильном монтаже грозит опасность тяжелых травм! Обязательным является немецкий текст данной инструкции.
- S** Dragkroken är en säkerhetskompoment och bör endast monteras av kvalificerade tekniker. Vid felaktig montering föreligger risk för allvarliga olyckor! Den tyska texten i denna anvisning är bindande.